



GE Plastics



GE Engineering
Thermoplastics

PRODUCT GUIDE

ULTEM[®]

PEI Resin

DISCLAIMER: THE MATERIALS AND PRODUCTS OF THE BUSINESSES MAKING UP THE GE PLASTICS UNIT OF GENERAL ELECTRIC COMPANY, USA, ITS SUBSIDIARIES AND AFFILIATES (“GEP”), ARE SOLD SUBJECT TO GEP’S STANDARD CONDITIONS OF SALE, WHICH ARE INCLUDED IN THE APPLICABLE DISTRIBUTOR OR OTHER SALES AGREEMENT, PRINTED ON THE BACK OF ORDER ACKNOWLEDGMENTS AND INVOICES, AND AVAILABLE UPON REQUEST. ALTHOUGH ANY INFORMATION, RECOMMENDATIONS, OR ADVICE CONTAINED HEREIN IS GIVEN IN GOOD FAITH, GEP MAKES NO WARRANTY OR GUARANTEE, EXPRESS OR IMPLIED, (I) THAT THE RESULTS DESCRIBED HEREIN WILL BE OBTAINED UNDER END-USE CONDITIONS, OR (II) AS TO THE EFFECTIVENESS OR SAFETY OF ANY DESIGN INCORPORATING GEP MATERIALS, PRODUCTS, RECOMMENDATIONS OR ADVICE. EXCEPT AS PROVIDED IN GEP’S STANDARD CONDITIONS OF SALE, GEP AND ITS REPRESENTATIVES SHALL IN NO EVENT BE RESPONSIBLE FOR ANY LOSS RESULTING FROM ANY USE OF ITS MATERIALS OR PRODUCTS DESCRIBED HEREIN. Each user bears full responsibility for making its own determination as to the suitability of GEP’s materials, products, recommendations, or advice for its own particular use. Each user must identify and perform all tests and analyses necessary to assure that its finished parts incorporating GEP materials or products will be safe and suitable for use under end-use conditions. Nothing in this or any other document, nor any oral recommendation or advice, shall be deemed to alter, vary, supersede, or waive any provision of GEP’s Standard Conditions of Sale or this Disclaimer, unless any such modification is specifically agreed to in a writing signed by GEP. No statement contained herein concerning a possible or suggested use of any material, product or design is intended, or should be construed, to grant any license under any patent or other intellectual property right of General Electric Company or any of its subsidiaries or affiliates covering such use or design, or as a recommendation for the use of such material, product or design in the infringement of any patent or other intellectual property right.

ULTEM®, LEXAN®, CYCOLAC®, CYCOLOY®, GELOY®, NORYL®, VALOX®, VERTON®, STARFLAM®, SUPEC® and XENOY® are registered trademarks of General Electric Company, USA.

XYLEX™ is a trademark of General Electric Company, USA.

Contents

<i>Title Page</i>	1	<u>2.6</u> Telecom, Molded Interconnect Devices (MIDs)	8
<i>Disclaimer</i>	2	<u>2.7</u> Electrical and Lighting	9
<i>Contents</i>	3	<u>2.8</u> HVAC / Fluid Handling	9
1 Introduction	4	3 Product Selection	10
2 Applications	5	<u>3.1</u> Product Description	10
<u>2.1</u> Tableware / Catering	5	<u>3.1.1</u> ULTEM® 1000 resin series Base Polymer ...	10
<u>2.2</u> Medical	6	<u>3.1.2</u> ULTEM® 2000 resin series	10
<u>2.3</u> Aircraft	6	<u>3.1.3</u> ULTEM® 3000 resin series	10
<u>2.4</u> Automotive	7	<u>3.1.4</u> ULTEM® 4000 resin series	10
<u>2.5</u> Automotive Lighting	8	<u>3.1.5</u> ULTEM® CRS 5000 resin series	10
		<u>3.1.6</u> ULTEM® 6000 resin series	10
		<u>3.1.7</u> ULTEM® 7000 resin series	10
		<u>3.1.8</u> ULTEM® 9000 resin series	10
		<u>3.1.9</u> ULTEM® ATX resin series (polyetherimide / polycarbonate-ester blend)	10
<u>3.2</u> Selection Tree	11	5 Design	32
<u>3.3</u> Heat - Impact – Flow Comparison	16	6 Processing	33
<u>3.4</u> Heat - Modulus – Flow Comparison	17	<u>6.1</u> Materials	33
4 Properties	18	<u>6.2</u> Mold Design	34
<u>4.1</u> Thermal Properties	18	<u>6.3</u> Equipment	35
<u>4.2</u> Flammability	19	<u>6.4</u> Molding Conditions	38
<u>4.3</u> Mechanical Properties	20	7 Secondary Operations	44
<u>4.4</u> Electrical Properties	23	<u>7.1</u> Welding	44
<u>4.5</u> Environmental Resistance	27	<u>7.2</u> Adhesives	44
		<u>7.3</u> Mechanical Assembly	44
		<u>7.4</u> Painting	45
		<u>7.5</u> Metallization	45

1 Introduction **ULTEM®** Polyetherimide Resins



ULTEM® Polyetherimide resin, PEI, is an amorphous high performance polymer which is characterized by excellent thermal properties, good chemical resistance, inherent flame retardancy and exceptional dimensional stability.

The base polymer ULTEM® 1000 resin has a transparent amber brown color, is manufactured by polycondensation and has the following chemical structure:

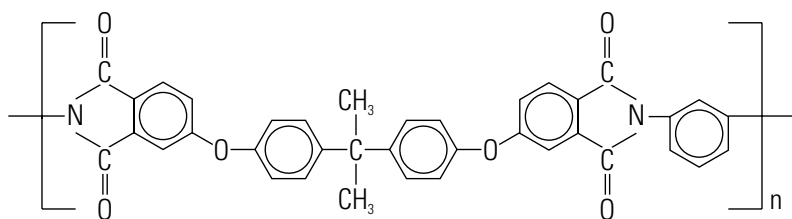

Key properties of the ULTEM® 1000 resin base polymer are:

- High long-term heat resistance exhibiting a glass transition temperature (T_g) of 217°C, HDT/Ae of 190°C and relative thermal index (RTI) of 170°C
- Inherent flame retardancy with low smoke evolution, meeting ABD, FAR and NBS requirements
- Excellent dimensional stability (low creep sensitivity and low, uniform coefficient of thermal expansion)
- Exceptional strength and modulus at elevated temperatures
- Good resistance to a broad range of chemicals such as automotive fluids, fully halogenated hydrocarbons, alcohols and aqueous solutions

- Stable dielectric constant and dissipation factor over a wide range of temperatures and frequencies
- Transparency to visible light, infrared light and microwave radiation
- Compliancy with FDA, EU, national food contact regulations and USP Class VI
- Outstanding processibility on conventional molding equipment

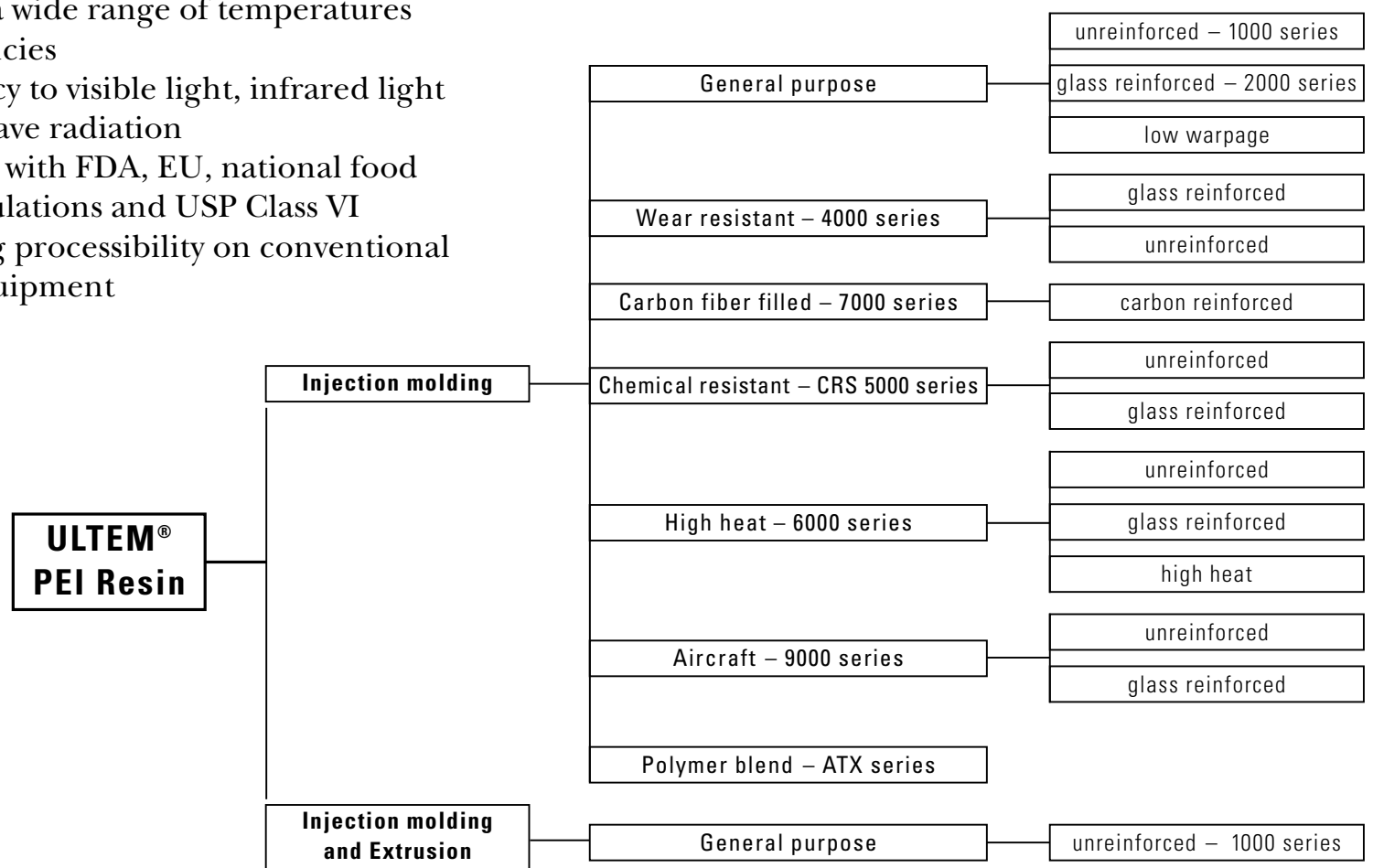

2 Applications

Tableware / Catering

Medical

Aircraft

Automotive

Automotive Lighting

**Telecom, Molded Interconnect
Devices (MIDs)**

Electrical and Lighting

HVAC / Fluid Handling



2.1 Tableware / Catering

High performance and design flexibility allow ULTEM® resin to be used for a wide variety of high quality, reusable food service applications which can be recycled after their service life. Examples are food trays, soup mugs, steam insert pans or gastronorm containers, cloches, microwavable bowls, ovenware, cooking utensils and re-usable airline casseroles.

ULTEM® resin in tableware and catering offers:

- Temperature resistance up to 200°C for hot air ovens
- Excellent infra-red and microwave transparency for fast reheating of food
- Reheating in combi-steamer and thermal contact heater
- Proven property retention through over 1000 cycles in industrial washing machines with detergents



- Excellent stain resistance even with stain-prone products like tomato ketchup, carrots and barbecue sauce
- Compliancy with FDA, EU and national food contact regulations
- Resistance against most cooking oils and greases
- Long-term hydrolytic stability
- Practical level of impact resistance (from subzero to 200°C)
- Cold touch (heated trays made from ULTEM® resin can be easily handled by hands)
- ULTEM® ATX resin series for superior impact behavior and intermediate thermal performance
- ULTEM® resin series for superior impact behavior and similar heat performance to ULTEM® 1000 resin

2.2 Medical

ULTEM® resin provides value added performance for reusable medical devices like sterilization trays, stopcocks, dentist devices and pipettes.

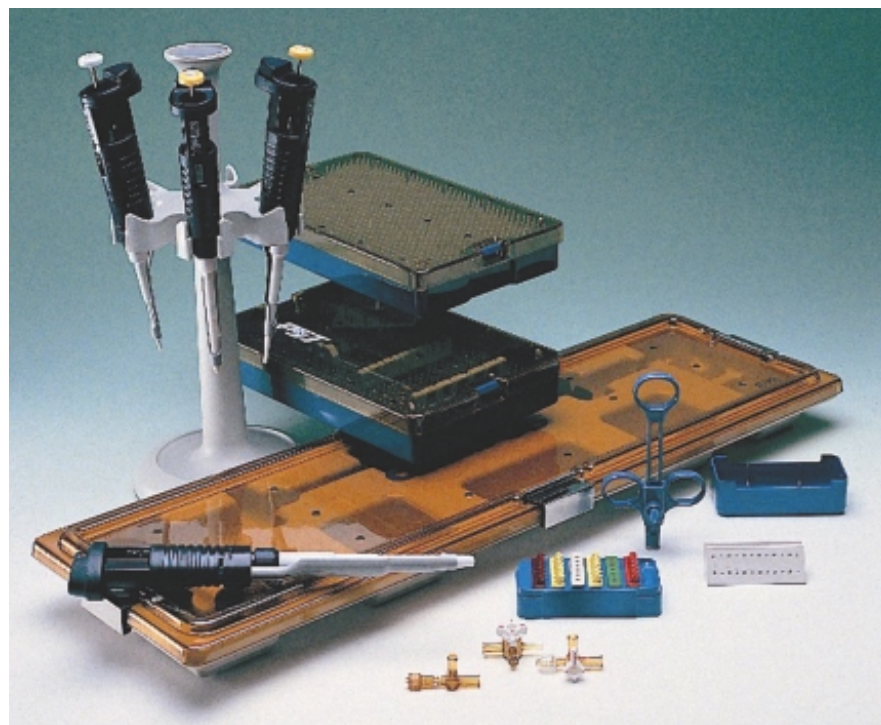

The reasons why ULTEM® resin can be the right choice for medical applications are:

- Full compliance with ISO10993, FDA and USP Class VI
- Ability to withstand various sterilization methods like EtO gas, gamma radiation, autoclaving and dry heat
- Excellent chemical resistance against most of the lipids, detergents and disinfectants
- ULTEM® 1000E transparent grade offers lower residual stress and increased toughness

2.3 Aircraft

The inherently flame retardant ULTEM® resin product family is widely used in the aircraft industry in applications like air and fuel valves, food tray containers, steering wheels, interior cladding parts and (semi-)structural components.



Goodrich Hella Aerospace Lighting Systems made the new passenger service unit using ULTEM® resin.

ULTEM® resin is chosen because it offers:

- The ULTEM® 9000 resin series for full compliance with aircraft industry regulations for aircraft interiors including ABD 0031, FAR 25.853, OSU 65/65 heat release tests and NBS smoke density tests
- The ULTEM® 1000, 2000, CRS 5000, 6000 and 7000 resin series for compliance with aircraft industry regulations such as ABD 0031, FAR 25.853, OSU 100/100 heat release tests and NBS smoke density tests
- Very low smoke and toxic gas emission, which makes it a material of choice for aircraft interiors
- Chemical resistance against most fuels and fluids
- Excellent processibility with a very good part reproducibility
- ULTEM® CRS 5000 resin series for better resistance against hydraulic aircraft fluids, such as Skydrol, compared to ULTEM® 1000 resin

- Ability to manufacture ULTEM® resin based thermoplastic composites which allow increased productivity in component manufacturing over traditional composite materials
- Ability to manufacture ULTEM® foam cores for tough, light-weight sandwich panels



2.4 Automotive

ULTEM® resin in the automotive industry provides manufacturers with a high performance, cost-effective alternative to metal: strong enough to replace steel in some applications and light enough to replace aluminum in others.

For applications like transmission components, throttle bodies, ignition components, sensors and thermostat housings, ULTEM® resin can offer:

- Heat resistance up to 200°C, RTI of 170°C
- Chemical resistance against most automotive fuels, fluids and oils
- Excellent dimensional stability (low creep sensitivity and low, uniform coefficient of thermal expansion)
- Superior torque strength and torque retention
- Excellent processibility with very tight molding tolerances
- Elimination of secondary operations like machining and anodizing



2.5 Automotive Lighting

The ULTEM® resin product family can be a specifically good fit in a heat dominated area like automotive lighting.

Typical applications are headlight reflectors, foglight reflectors, bezels and light bulb sockets where ULTEM® resin can provide:



- High heat resistance up to 200°C, RTI of 170°C
- Metallization without primer
- Competitive system cost vs. traditional thermoset materials
- Design and processing flexibility which allows typical free form reflector design
- Integration possibilities for mounting and adjustment fixings
- Infra-red transparency allowing heat dissipation
- Weight savings because of lighter, thinner walled reflectors than possible with traditional thermoset materials
- Excellent dimensional stability (low creep sensitivity and low, uniform coefficient of thermal expansion)
- Easier recyclability of ULTEM® resin versus the “traditional” materials
- ULTEM® 1010M grade offers improved processability in metallized lighting applications

2.6 Telecom, Molded Interconnect Devices (MIDs)

Its unique plating capabilities make ULTEM® resin the material of choice for Telecom and MID applications. ULTEM® resin allows the combination of electrical functions with the advantages of injection molded three-dimensional mechanical components in: electrical control units, computer components, mobile phone internal antennae, rf-duplexers or microfilters and fiber optic connectors.

ULTEM® resin can offer:

- Unique plating capabilities with the chemical bonding process
- Significant productivity through integration of components and ease of assembly through, among others, snap fits
- High heat resistance up to 200°C
- Stable dielectric constant and dissipation factor over a wide range of temperatures (subzero to 200°C) and frequencies (1 Hz - 10¹⁰ Hz)

- Excellent dimensional stability (low creep sensitivity and low, uniform coefficient of thermal expansion)
- Consistent processability and therefore reproducibility of parts
- ULTEM® resin EPR grades offer enhanced flow and platability versus ULTEM® filled grades.

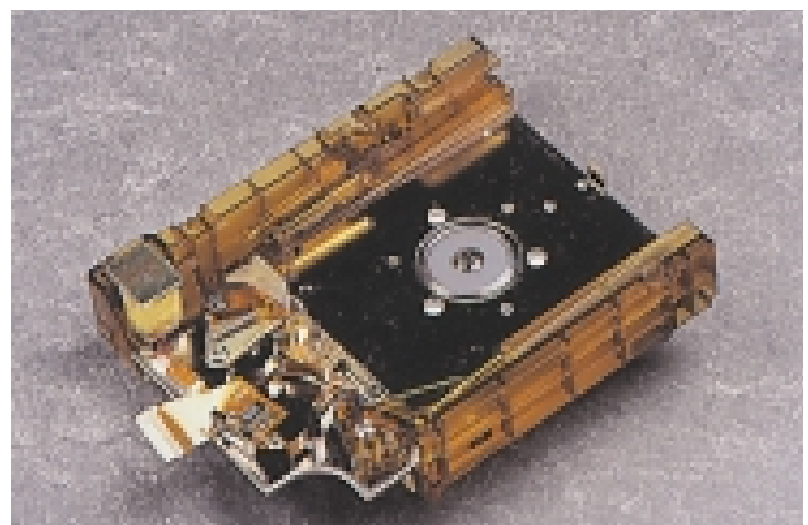

2.7 Electrical and Lighting

From connectors to reflectors, ULTEM® resin is the material of choice for today's demanding electrical and lighting applications.

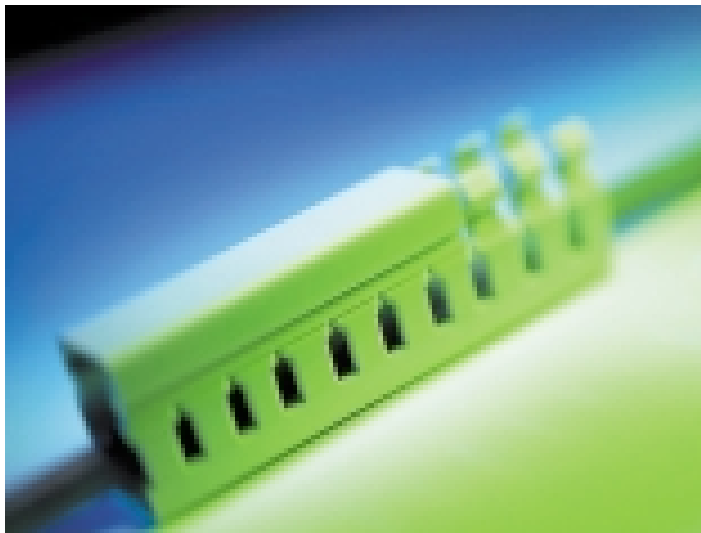

In these segments ULTEM® resin can provide:

- Temperature resistance up to 200°C, RTI of 170°C and ball pressure test at 125°C
- Excellent dimensional stability (low creep sensitivity and low, uniform coefficient of thermal expansion)
- Compatibility with UL file E75735 for use as insulation materials in transformers and motors of up to 600 volts
- Inherent flame retardancy
- Passes glow wire test at 960°C (1-3.2 mm)
- Low water absorption
- ULTEM® grades with F0 and F1 classification according to the French Standard for Transportation NF F 16-101
- Suitability for use with dichroic coating without primer for reflectors
- ULTEM® 6000 resin series for high heat connectors

2.8 HVAC/Fluid Handling

In circumstances where heat and fluids are combined in an application, ULTEM® resin can offer an ideal balance of properties.

For applications like water-pump impellers, expansion valves, hot water reservoirs and heat exchange systems, ULTEM® resin is chosen because it offers:

- Long-term heat resistance, RTI of 170°C

- Weld line strength, needed because of high temperatures and dynamic pressures
- Potable water approval up to 90°C (KTW approval)
- Excellent mechanical properties under hot water conditions
- Good hydrolytic stability
- Excellent dimensional stability (low creep sensitivity and low, uniform coefficient of thermal expansion)



3 Product Selection

3.1 Product Description

3.1.1 ULTEM® 1000 resin series Base Polymer

- General purpose
- Unreinforced
- Food contact compliant grades available
- USP Class VI compliant grades available
- Low viscosity grades available
- Extrusion and injection molding grades

3.1.2 ULTEM® 2000 resin series

- Glass reinforced
- Greater rigidity vs. ULTEM® 1000 resin
- Improved dimensional stability over ULTEM® 1000 resin
- Low viscosity grades available
- EPR series has four-times higher plating adhesion and 30% better flow than standard ULTEM® 2000 filled products

3.1.3 ULTEM® 3000 resin series

- Glass and mineral filled
- High strength
- Improved dimensional stability versus ULTEM® 2000 series

3.1.4 ULTEM® 4000 resin series

- Wear resistance
- Reduced coefficient of friction
- Unreinforced and glass reinforced grades

3.1.5 ULTEM® CRS 5000 resin series

- Superior chemical resistance over ULTEM® 1000 resin
- Better resistance against hydraulic aircraft fluids compared to ULTEM® 1000 resin
- Unreinforced and glass reinforced grades

3.1.6 ULTEM® 6000 resin series

- Highest heat resistance of all ULTEM® resin grades

3.1.7 ULTEM® 7000 resin series

- Carbon fiber-reinforced
- Exceptional strength-to-weight ratio
- Highest modulus of all ULTEM® resin grades

3.1.8 ULTEM® 9000 resin series

- Fulfills aircraft industry regulations (ABD, FAR, OSU and NBS)
- Delivered with individual lot certification
- Unreinforced and glass reinforced grades
- Extrusion and injection molding grades

3.1.9 ULTEM® ATX resin series (polyetherimide/polycarbonate-ester blend)

- Intermediate heat performance
- ULTEM® ATX 100 resin offers higher impact performance compared to ULTEM® 1000 resin
- Very high flow compared to ULTEM® 1000 resin
- Metallizable without primer
- Food contact compliant grades available

3.2 Selection Tree

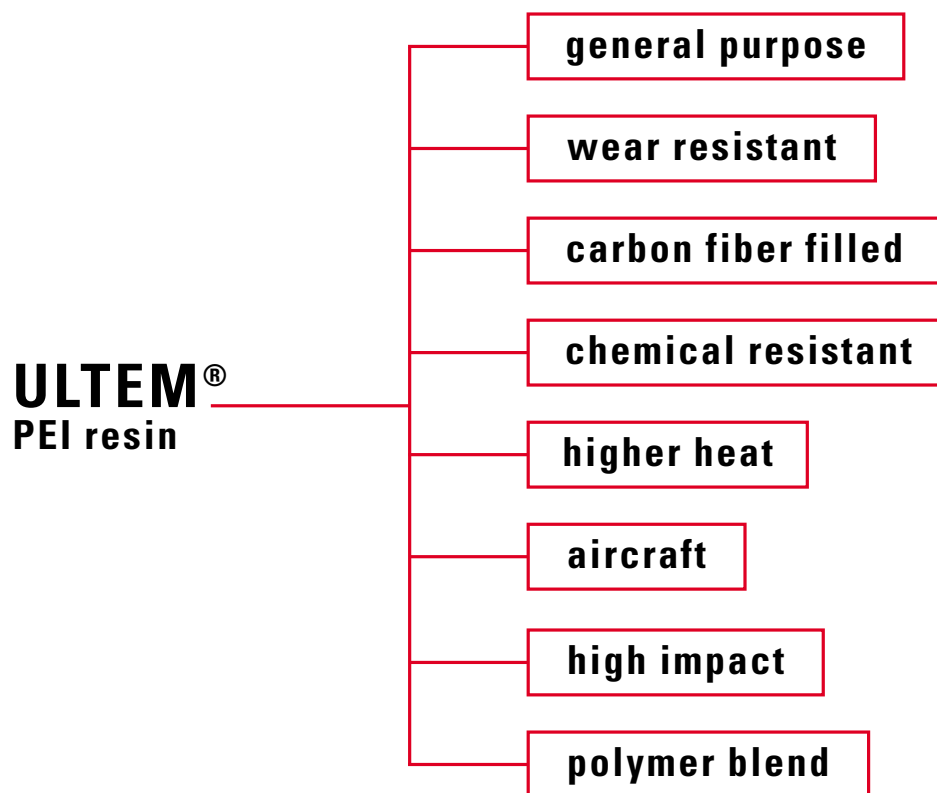

GRADE	Heat • Impact • Modulus Flammability • Flow
Grade:	All are injection molding grades unless otherwise indicated.
(R):	Standard mold release, non-transparent, non-food contact
(M):	Optimized standard mold release for metallized reflectors
(F):	Food contact
(E):	Mold release, transparent
(P):	Powder
(EPR)	Enhanced plating, release containing
(Std.)	Standard
(HF):	High flow
(S):	Special filtered
(X):	Improved low ionic capabilities
Heat:	HDT/Ae in °C (ISO 75)
Impact:	Izod Notched at 23°C in kJ/m ² (ISO 180/1A)
Impact*:	Izod Unnotched at 23°C in kJ/m ² (ISO 180/1U)
Modulus:	Flexural in MPa (ISO 178)
Flammability:	Recognized at mm thickness (UL94)
Flow:	MVR at 360°C/5.00kg in cm ³ /10min (ISO1133)
Flow*:	MVR at 320°C/2.16kg in cm ³ /10min (ISO1133)
n.t.:	not tested

ULTEM® PEI resin | general purpose | wear resistant | carbon fiber filled | chemical resistant
 | higher heat | aircraft | high impact | polymer blend

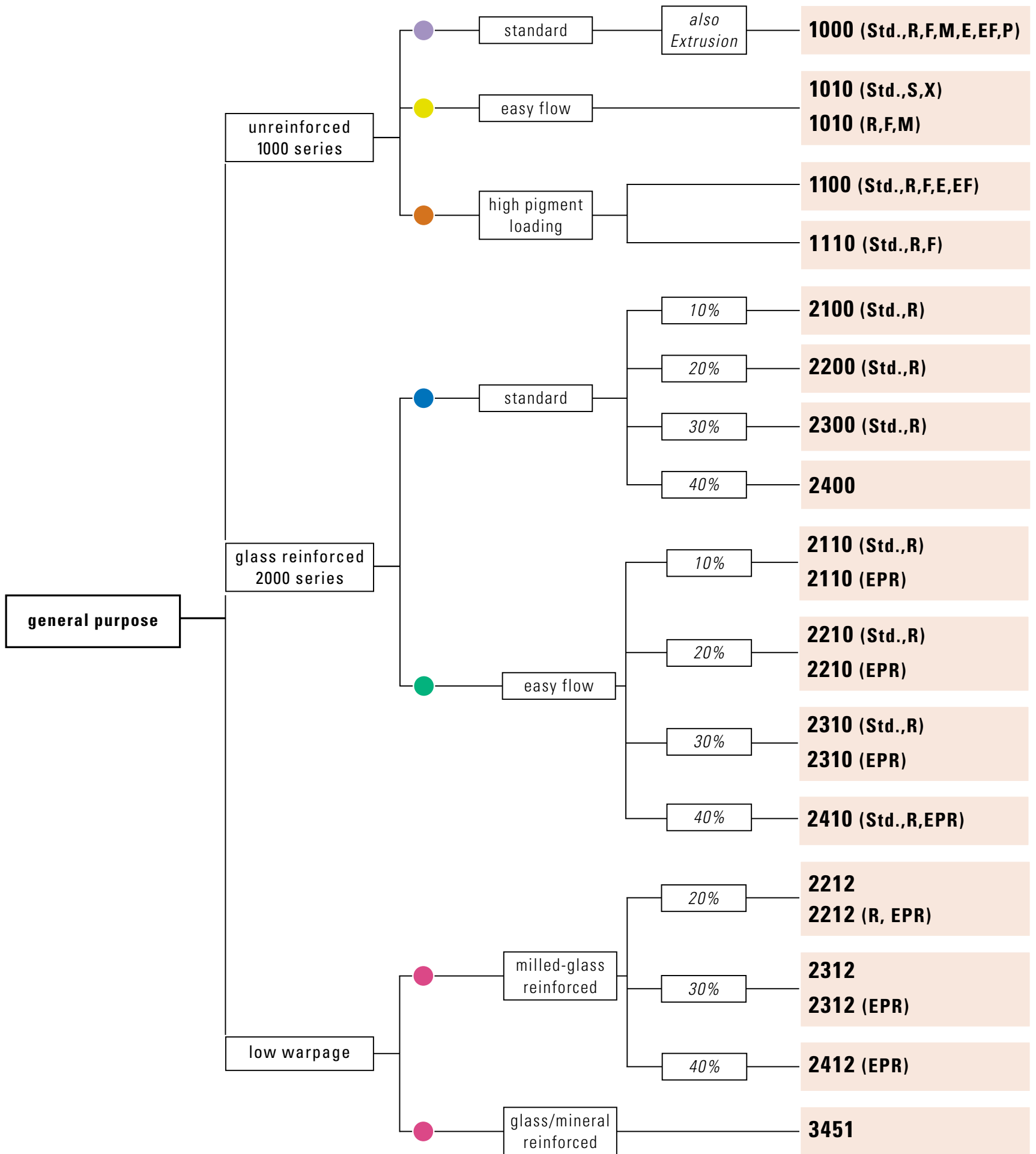

ULTEM® PEI resin | general purpose | wear resistant | carbon fiber filled | chemical resistant
 | higher heat | aircraft | high impact | polymer blend

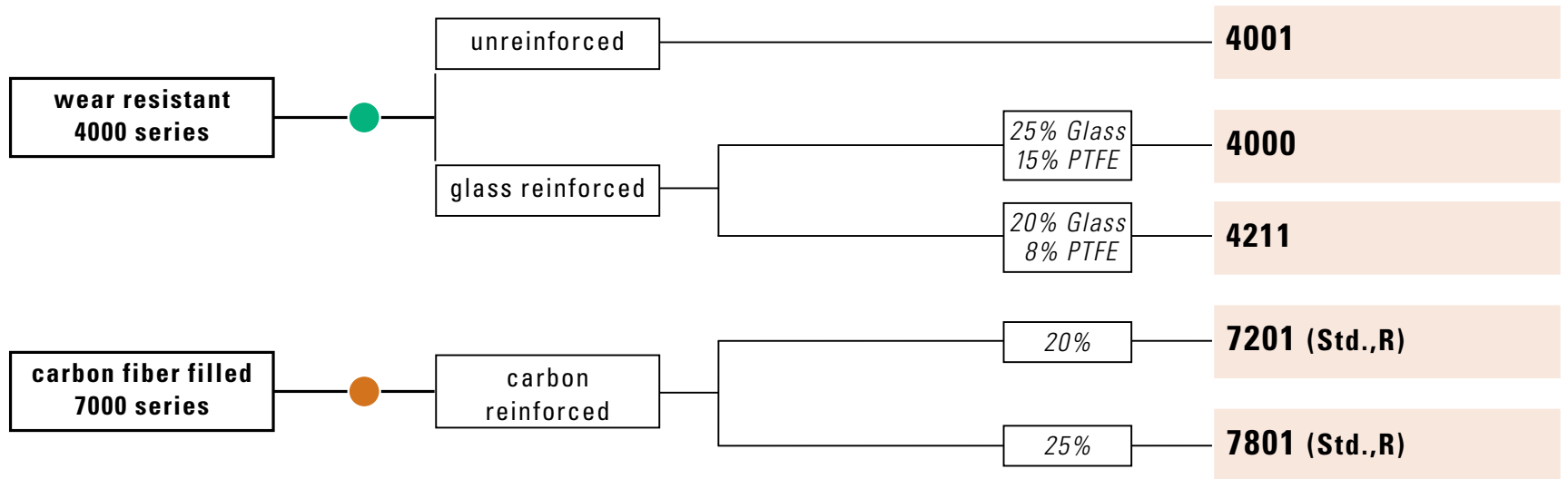

see charts on pages 16 and 17

ULTEM® PEI resin | general purpose | wear resistant | carbon fiber filled | chemical resistant
 | higher heat | aircraft | high impact | polymer blend

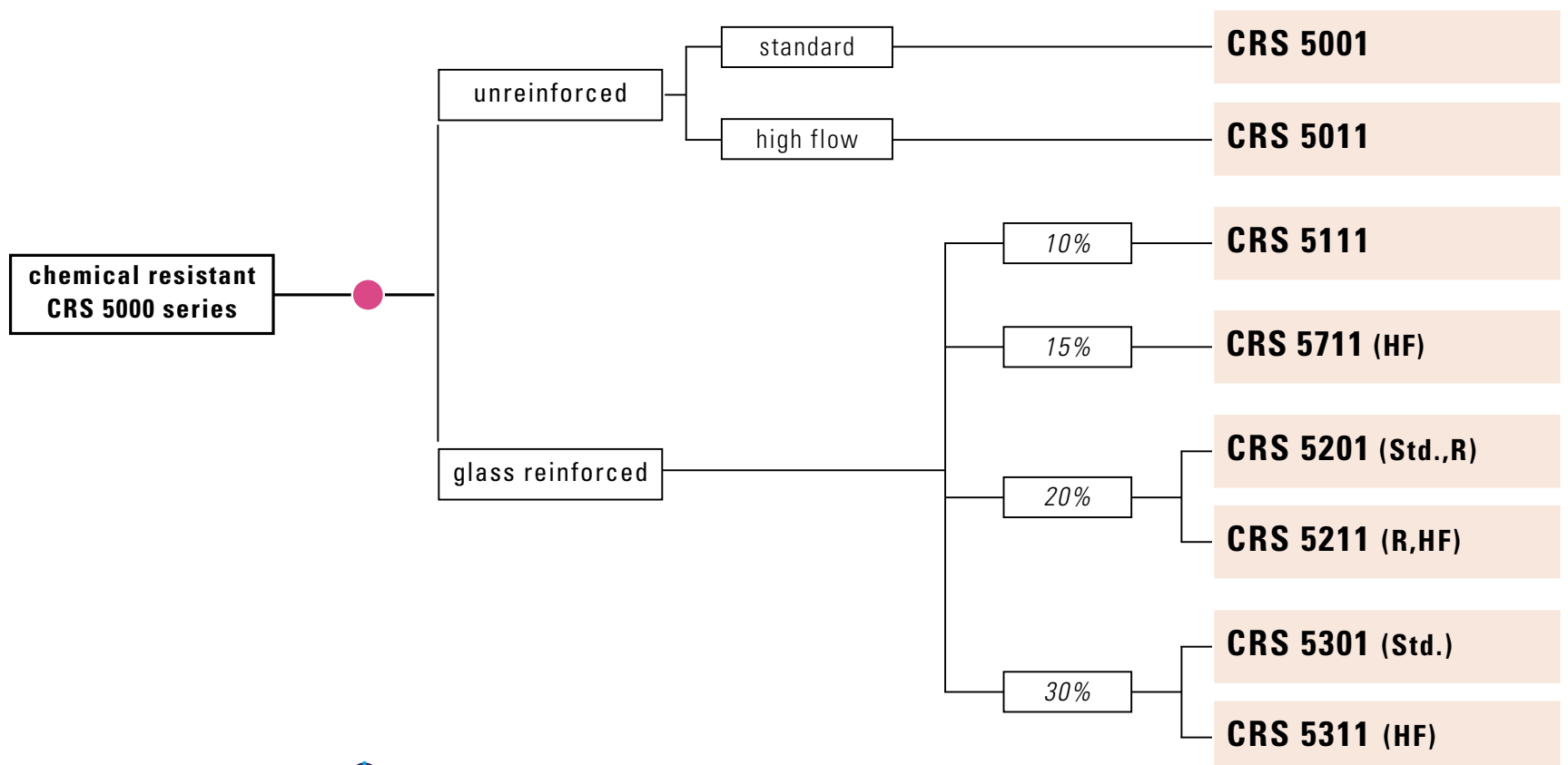

see charts on pages 16 and 17

ULTEM® PEI resin | general purpose | wear resistant | carbon fiber filled | chemical resistant
 | **higher heat** | aircraft | high impact | polymer blend

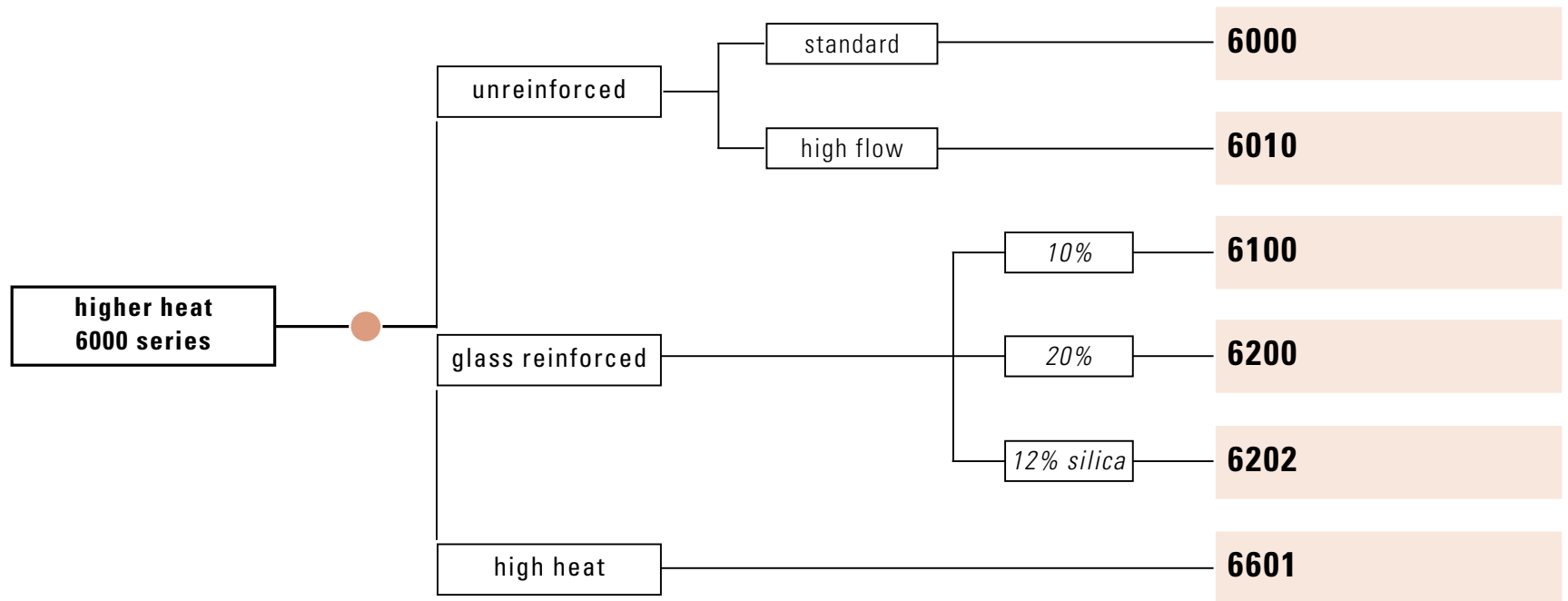

see charts on pages 16 and 17

ULTEM® PEI resin | general purpose | wear resistant | carbon fiber filled | chemical resistant
 | higher heat | **aircraft** | high impact | polymer blend

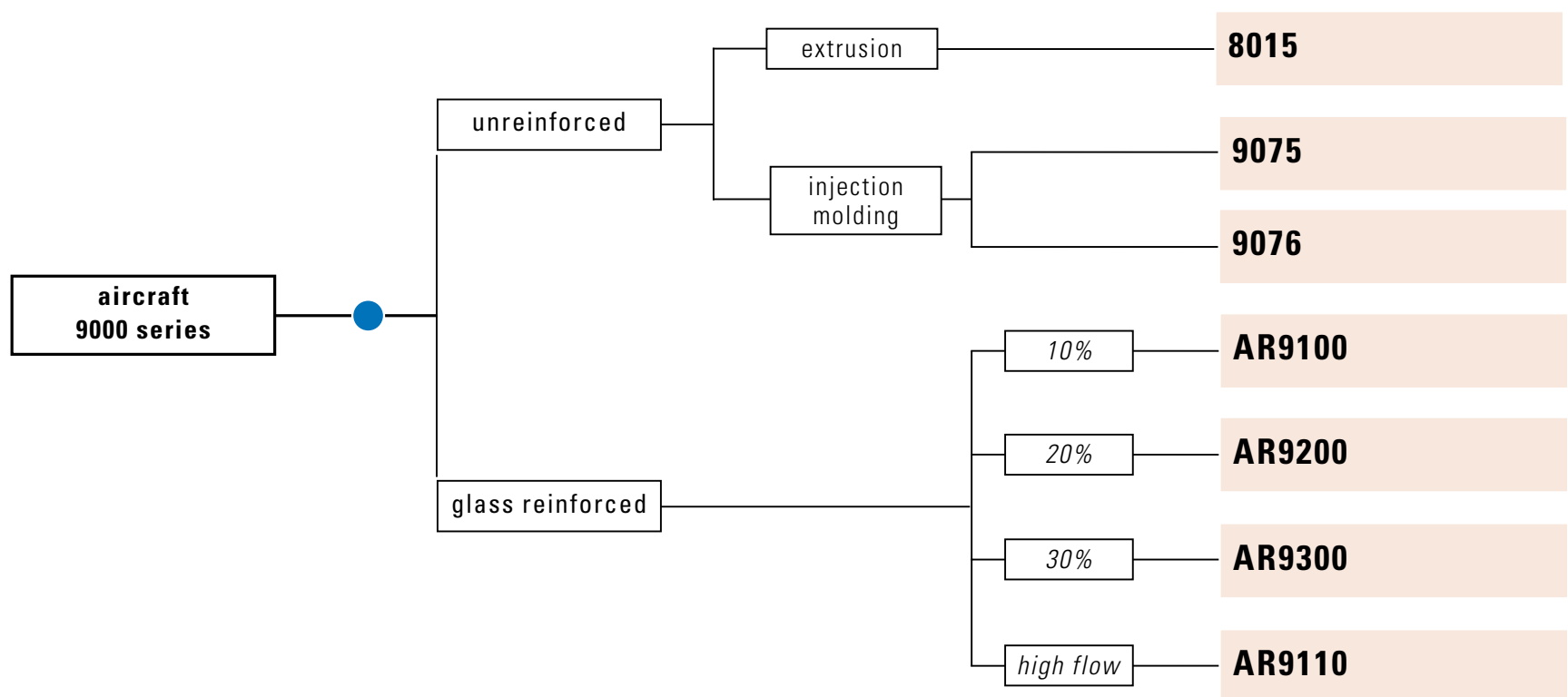

see charts on pages 16 and 17

ULTEM® PEI resin › general purpose | wear resistant | carbon fiber filled | chemical resistant
| higher heat | aircraft | **high impact** | **polymer blend**

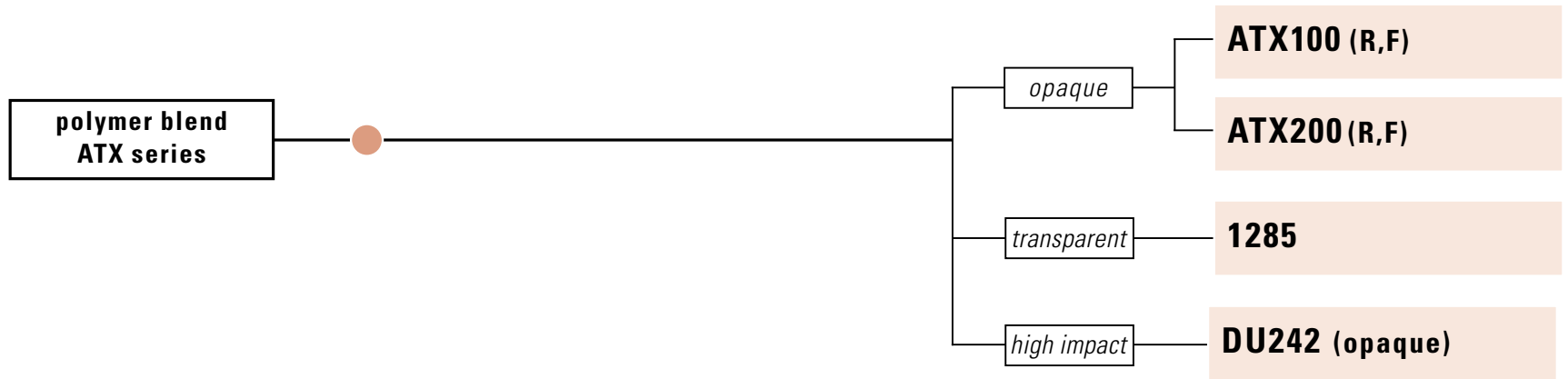

 see charts on pages 16 and 17

3.3 Heat-Impact – Flow Comparison

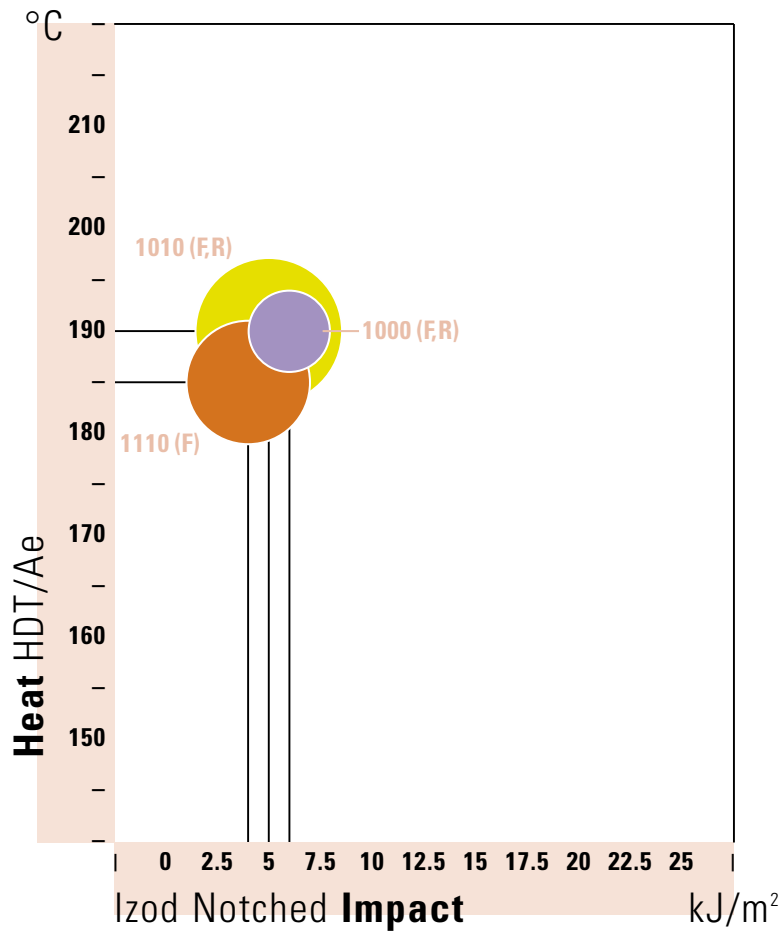

ULTEM® resin unreinforced
general purpose

- standard
- high flow
- high pigment loading

Flow Melt Volume Rate $\text{cm}^3/10 \text{ min}$

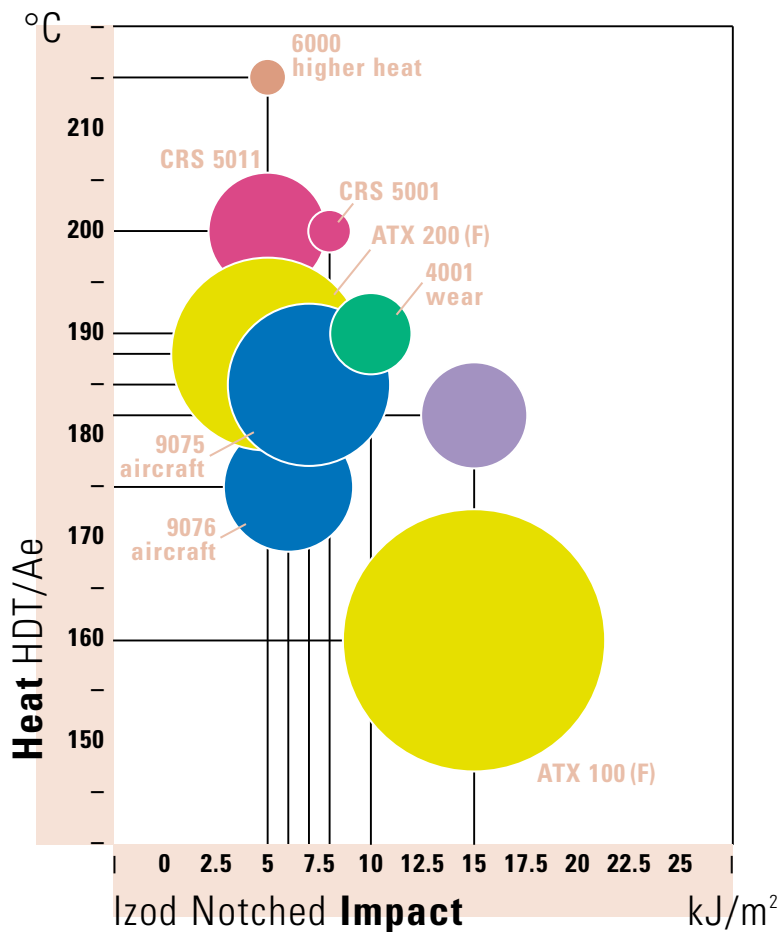
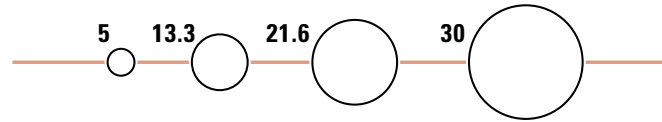

ULTEM® resin unreinforced
non general purpose

- wear resistant
- chemical resistant
- higher heat
- aircraft
- high impact
- polymer blend

Flow Melt Volume Rate $\text{cm}^3/10 \text{ min}$

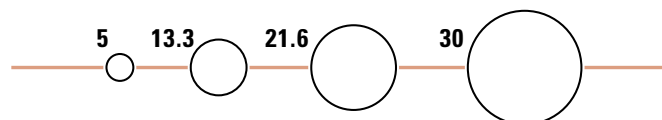

3.4 Heat-Modulus – Flow Comparison

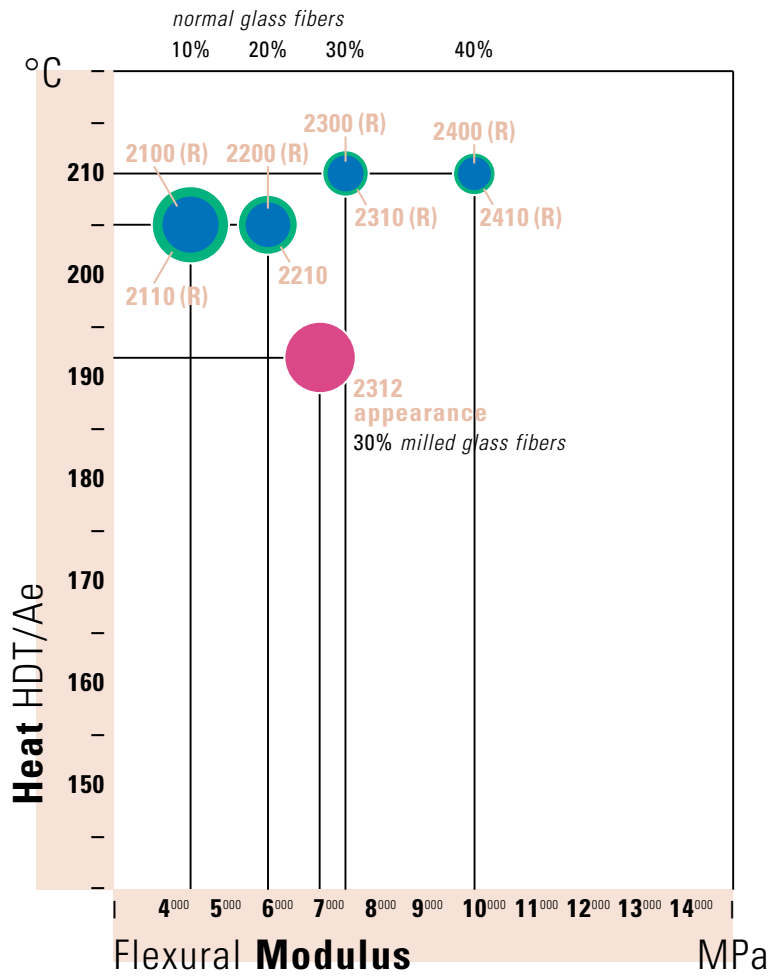

ULTEM® resin reinforced **general purpose**

- standard
- high flow
- milled glass

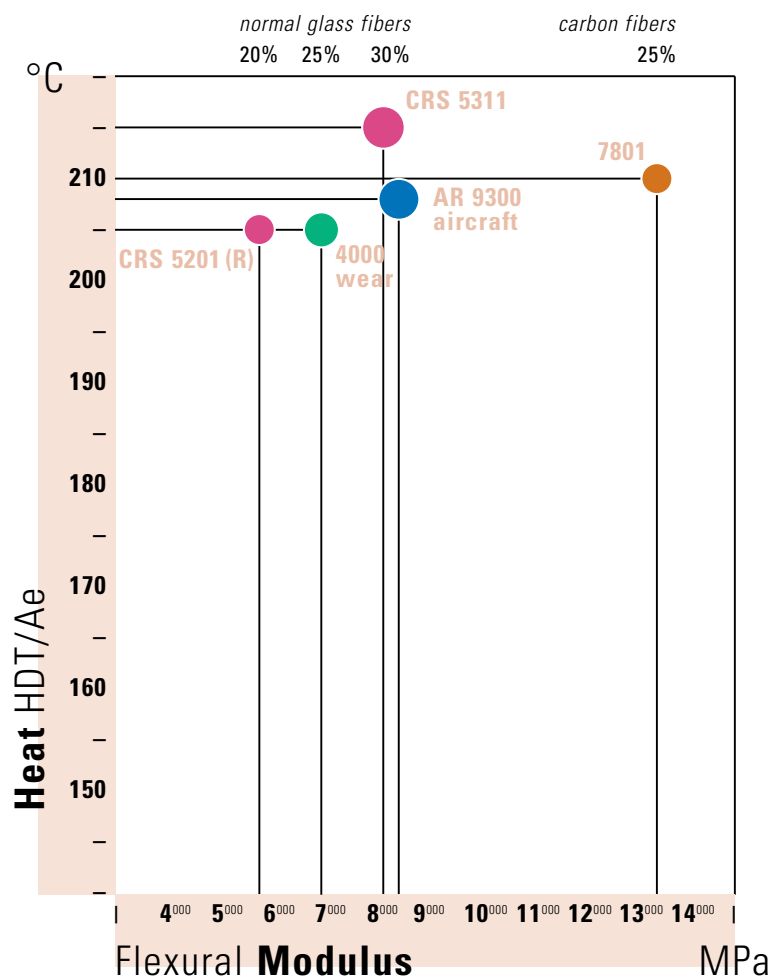
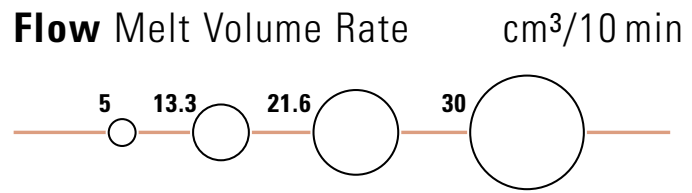

ULTEM® resin reinforced **non general purpose**

- wear resistant
- chemical resistant
- carbon fiber filled
- aircraft

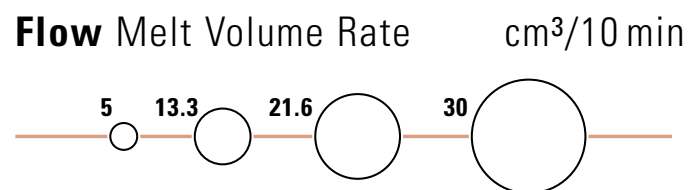

4 Properties*

4.1 Thermal Properties

An outstanding property of ULTEM® resin is its ability to withstand long-term exposure to elevated temperatures. This high heat performance, combined with excellent flammability ratings and Underwriters' Laboratory, UL, recognition, qualifies ULTEM® resin for demanding high temperature applications.

Heat deflection temperature and continuous use ratings

In recognition of its inherent thermal stability, UL has granted the ULTEM® 1000 resin base polymer a relative thermal index (RTI) of 170°C, according to UL746B. The polymer's high glass transition temperature (Tg) of 217°C coupled with its high heat deflection temperature (HDT/Ae 1.80 MPa) of 190°C contributes to its excellent retention of physical properties at elevated temperatures.

* Typical values only.

In all cases extensive testing of the application under the end-use working conditions is strongly recommended. The actual performance and interpreting of the results of end-use testing are the end-producer's responsibility.

■ FIGURE 4-1 shows the ability of ULTEM® resin to maintain this high heat deflection temperature with increased stress, an important consideration to the design engineer.

■ FIGURE 4-1

Heat deflection temperature of ULTEM® 1000 resin vs. applied stress

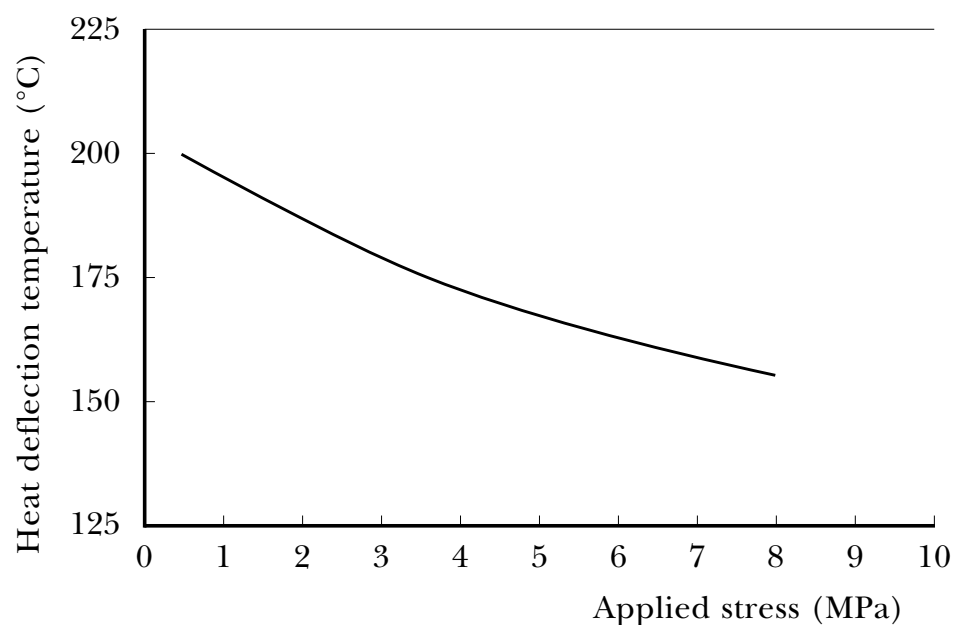

■ FIGURE 4-2 compares the high heat deflection temperature of ULTEM® 1000 resin with those of other high performance engineering thermoplastics.

■ FIGURE 4-2
Heat Deflection Temperature (HDT/Ae 1.80 MPa)

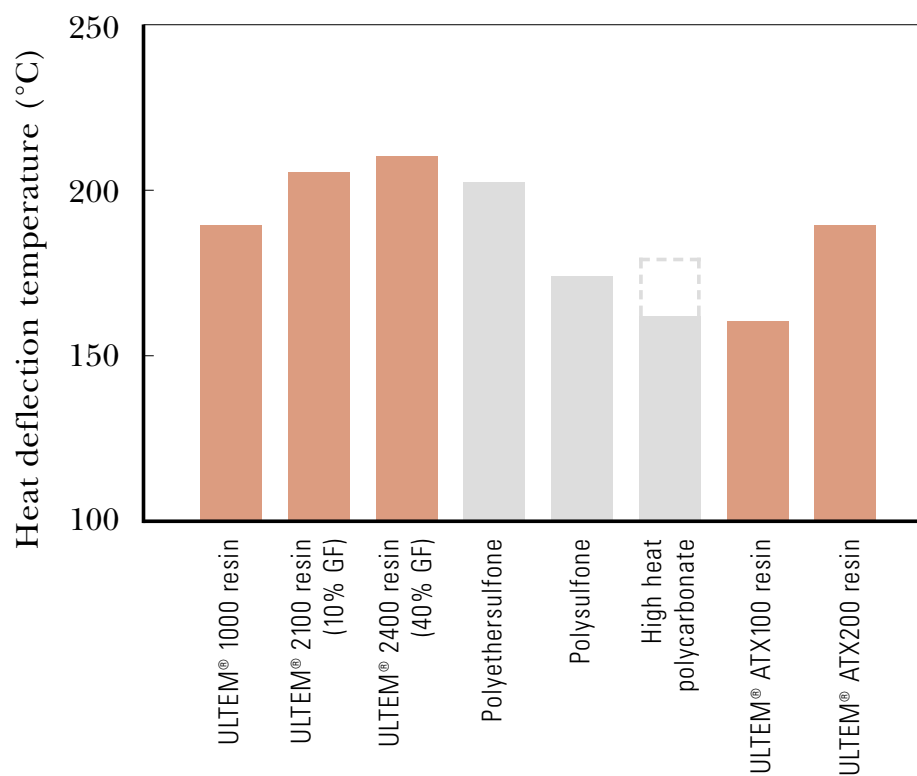

Coefficient of thermal expansion

Another important design consideration is the thermal expansion of a material, particularly in applications where plastic parts are mated with metal parts or have metal inserts. ■ TABLE 4-1 lists the coefficient of thermal expansion for the family of ULTEM® resin grades and demonstrates the capability of matching the values of several metals.

4.2 Flammability

Flame resistance

ULTEM® resin exhibits exceptionally good flame resistance without the use of additives. For example, ULTEM® 1000 resin has been rated V0 at 0.41 mm under UL94, and 5VA at 1.6 mm. In addition, as seen in ■ FIGURE 4-3, it has a limited oxygen index of 47, the highest of any commonly used engineering thermoplastic.

Combustion characteristics

A key factor in determining the relative safety of a polymeric material is its smoke generation under actual fire conditions. Measured against

■ TABLE 4-1

Coefficient of linear thermal expansion

Material	Flow direction (10 ⁻⁵ /°C)	Cross flow direction (10 ⁻⁵ /°C)
ULTEM® 1000 resin	5	5
ULTEM® 2100 resin	2.6	6
ULTEM® 2200 resin	2.5	6
ULTEM® 2300 resin	2	6
ULTEM® 2312 resin	2.3	2.7
ULTEM® 2400 resin	1.5	4.5
Polysulfone	5.6	
Polysulfone 10% GF	3.6	
High Heat Polycarbonate	7.5	
Brass	1.6-1.8	
Zinc	2.7	
Aluminum	2.2	
Steel	1.2-1.5	

■ FIGURE 4-3

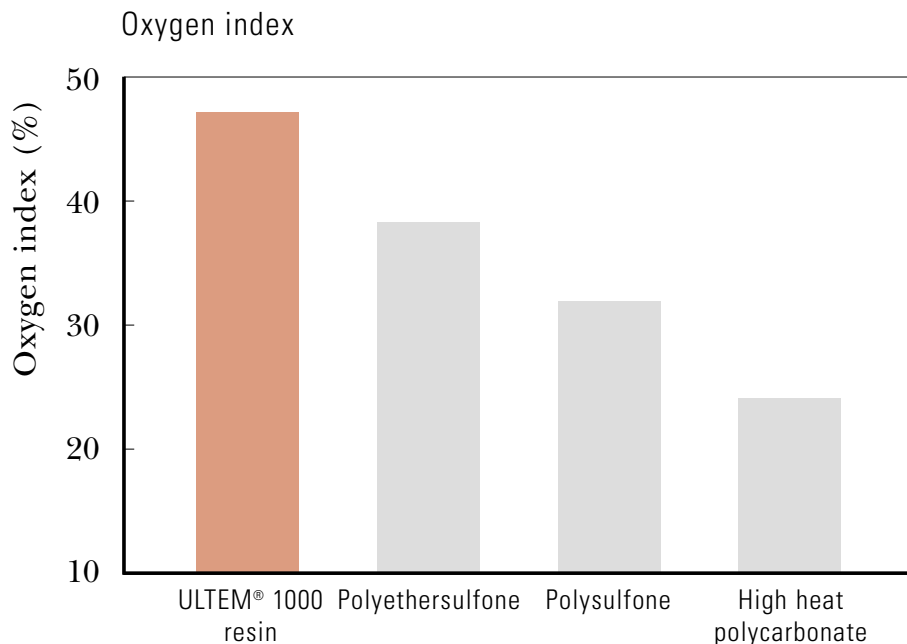

■ FIGURE 4-4

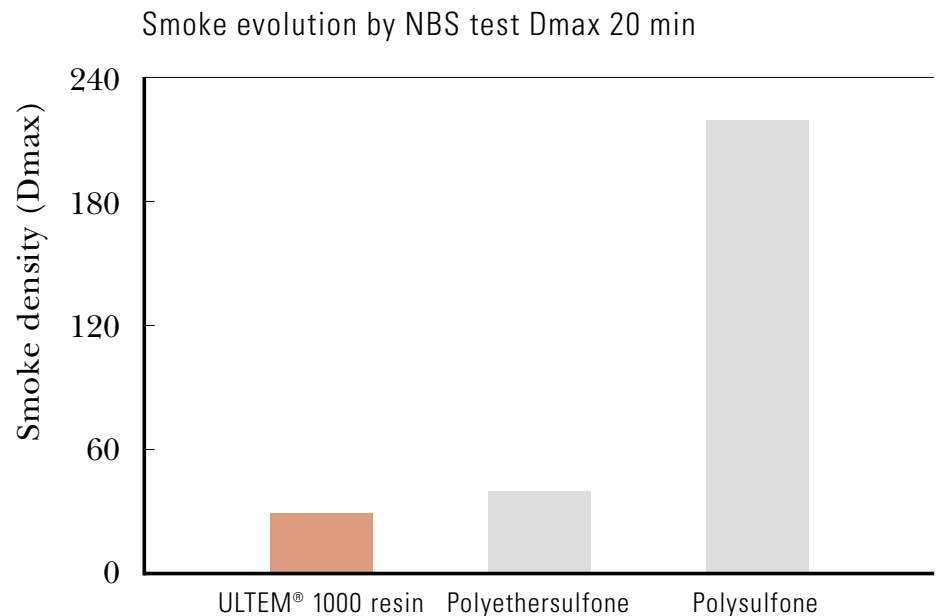

other engineering thermoplastics, ULTEM® resin exhibits extremely low levels of smoke generation as demonstrated by the NBS smoke evolution test results shown in ■ FIGURE 4-4. Furthermore, the products of combustion of ULTEM® resin have been shown to be no more toxic than those of wood.

Aircraft industry regulations

ULTEM® resin is widely used in aircraft applications because of its compliance with aircraft industry regulations. ■ TABLE 4-2 lists the performance of the different ULTEM® resin series according to these regulations.

4.3 Mechanical Properties

Strength

At room temperature, ULTEM® resin exhibits strength well beyond that of most engineering thermoplastics, with a tensile stress at yield of 105 MPa (ISO R527) and a flexural strength at yield of 160 MPa (ISO 178).

Even more impressive is the retention of strength at elevated temperatures. At 190°C, a temperature well beyond the useful range of most other engineering thermoplastics, ULTEM® resin retains approximately 50 MPa tensile stress (ISO R527), as illustrated in ■ FIGURE 4-5.

■ TABLE 4-2

Aircraft regulation compliance according to ABD 0031, FAR 25.853, OSU

Resin Grade	FAR	OSU 25.853	Smoke	Toxicity Ds 4min
ULTEM® 1000 resin series	a(60s)	100/100	<50	pass
ULTEM® 2000 resin series	a(60s)	100/100	<50	pass
ULTEM® CRS 5000 resin series	a(60s)	100/100	<50	pass
ULTEM® 6000 resin series	a(60s)	100/100	<50	pass
ULTEM® 7000 resin series	a(60s)	100/100	<50	pass
ULTEM® 9000 resin series	a(60s)	65/65	<50	pass

ABD 0031 contains requirements for smoke, toxicity and FAR 25.853.
 FAR 25.853 classifies materials for flammability.
 OSU (Ohio State University) calorimeter requirements for larger parts.

■ FIGURE 4-5

Tensile stress as a function of temperature

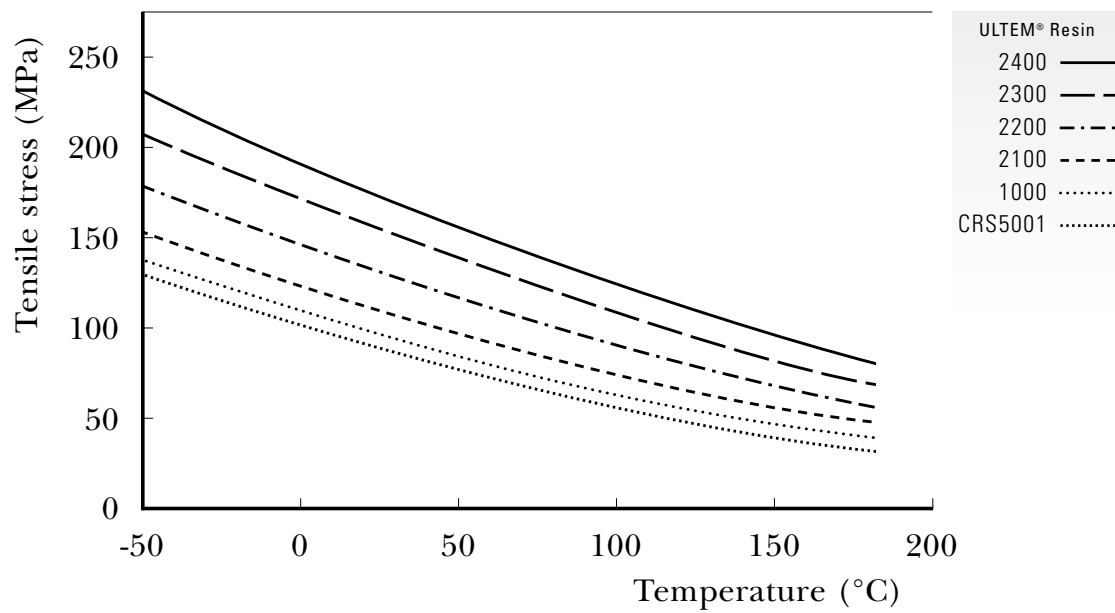

■ FIGURE 4-6 demonstrates the higher tensile stress of ULTEM® 1000 resin compared to other high performance engineering materials. The outstanding inherent strength of ULTEM® resin is further enhanced through reinforcement with glass fibers, as shown in ■ FIGURE 4-7 which compares ULTEM® 2200 resin (20% glass reinforced grade) with other glass reinforced engineering thermoplastics.

■ FIGURE 4-6

Tensile stress (23°C) at yield (50mm/min)

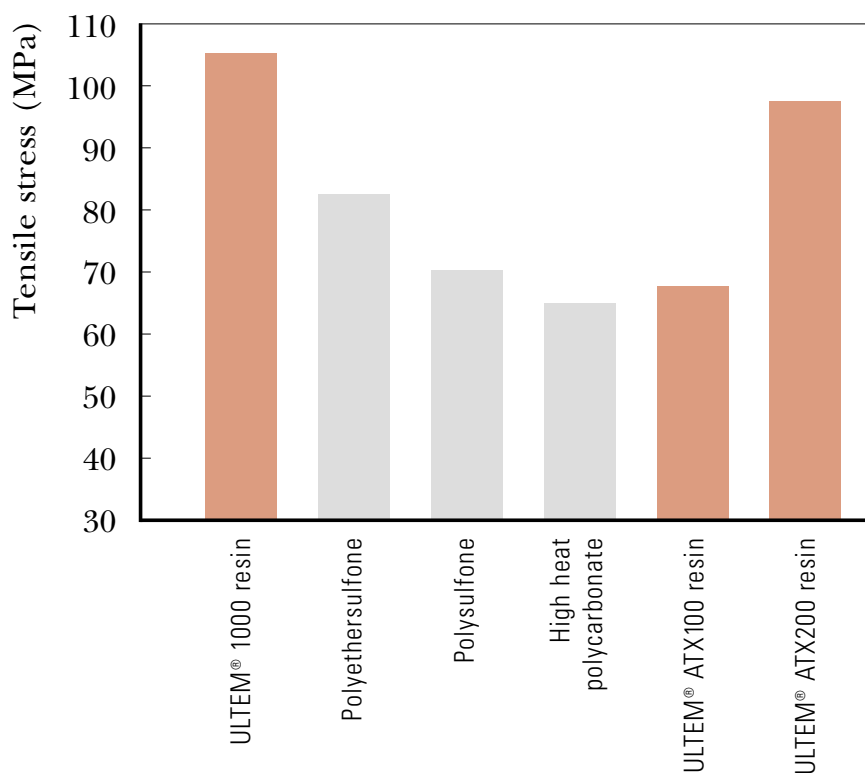

■ FIGURE 4-7

Tensile stress (23°C) at break (5mm/min)

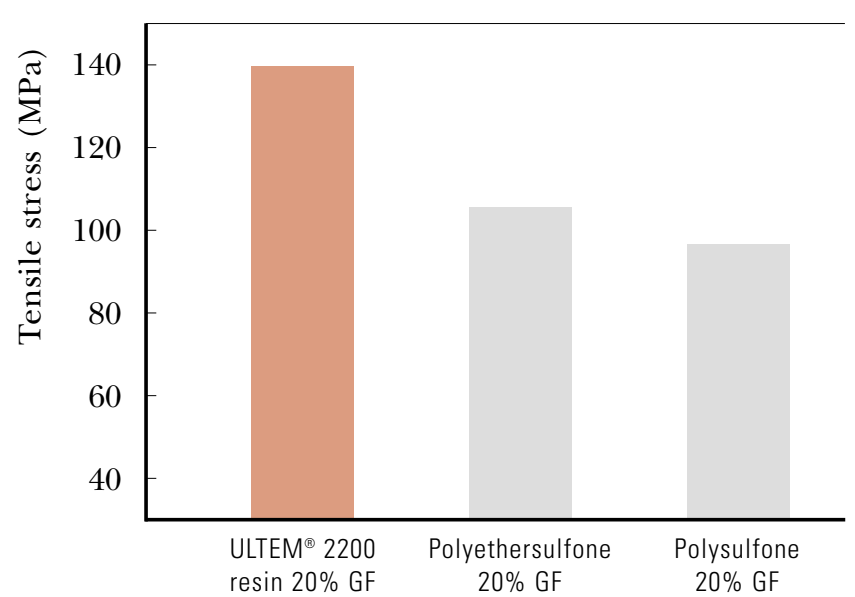

Modulus

Another outstanding mechanical property of ULTEM® PEI resin is its high modulus. The 3300 MPa flexural modulus (ISO 178) of ULTEM® 1000 resin is one of the highest room temperature moduli of any high performance engineering plastic. In load bearing applications where deflection is a primary consideration, unreinforced ULTEM® resin provides structural

rigidity approaching that of many glass reinforced resins. In addition, the flexural modulus of ULTEM® resin remains exceptionally high at elevated temperatures, as shown in ■ FIGURE 4-8. For example, at 175°C the modulus of ULTEM® 1000 resin is higher than that of most engineering plastic at room temperature.

■ FIGURE 4-8

Flexural modulus of ULTEM® resin at different glass ratios as a function of temperature vs. PPS 40%GF

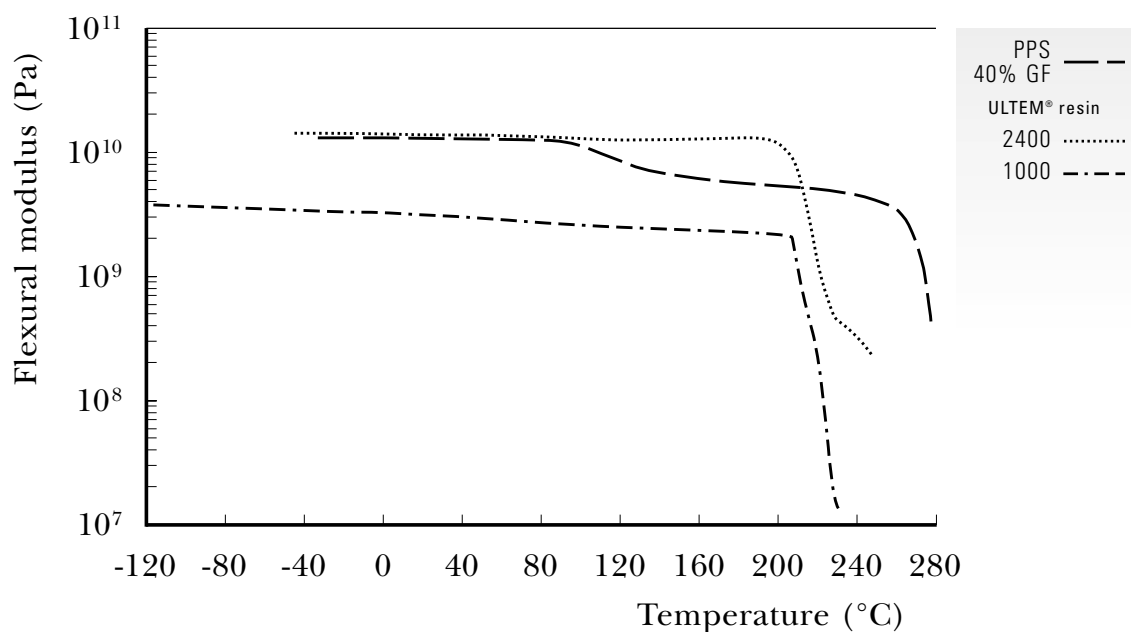

Thus, ULTEM® resin offers designers the opportunity to achieve desired stiffness with none of the sacrifices associated with glass reinforced materials, such as increased machine and tool wear and decreased flow.

■ FIGURE 4-9 compares the flexural modulus of the ULTEM® 1000 resin base polymer with that of other high performance engineering thermoplastics.

Where greater stiffness is required, the glass reinforced ULTEM® 2000 resin series or the carbon fiber reinforced ULTEM® 7000 resin series provide additional performance with flexural moduli as high as 13500 MPa (ISO 178) at room temperature.

■ FIGURE 4-9

Flexural modulus (23°C) 2 mm/min

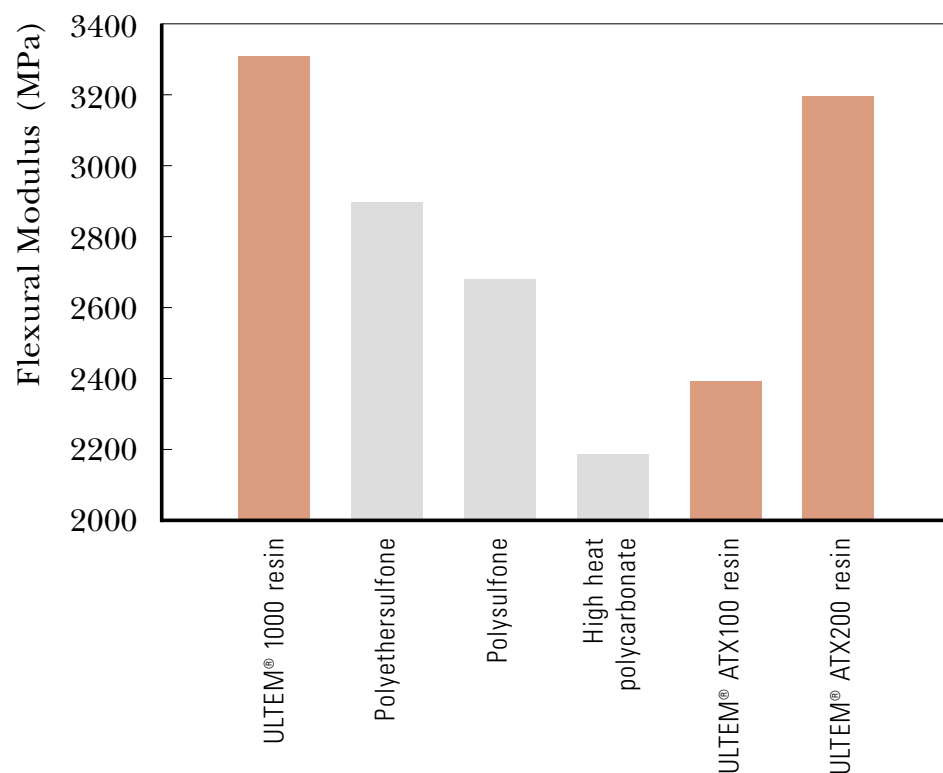

Ductility

In addition to its unique combination of high strength and modulus, ULTEM® resin exhibits outstanding ductility. Its tensile elongation at yield affords the freedom to incorporate snap fit designs for ease of assembly. Even with the addition of 10% glass reinforcement, ULTEM® 2100 resin retains ductility over a temperature range from subzero to 200°C.

Impact strength

ULTEM® 1000 resin exhibits excellent practical impact resistance. Since ULTEM® resins display notch sensitivity, adherence to standard design principles is recommended. Stress concentrators such as sharp corners should be minimized to provide the maximum impact strength in molded parts. ULTEM® ATX100 resin has been developed specifically for applications where high impact performance is required. The Izod notched impact strength of this series goes up to 15 kJ/m².

Fatigue endurance

Fatigue is an important design consideration for parts subjected to cyclical loading or vibration. In such applications, an uniaxial fatigue diagram (see ■ FIGURE 4-10) could be used to predict product life. These curves can be used to determine the fatigue endurance limit, or the maximum cycle stress that a material can withstand without failure.

Creep behavior

When considering the mechanical properties of any thermoplastic material, designers must recognize the effects of temperature, stress level and load duration on material performance. ULTEM® resin displays excellent creep resistance even at temperatures and stress levels which would preclude the use of many other thermoplastics.

■ FIGURE 4-10
Uniaxial fatigue test
of ULTEM® resin at
different glass ratios

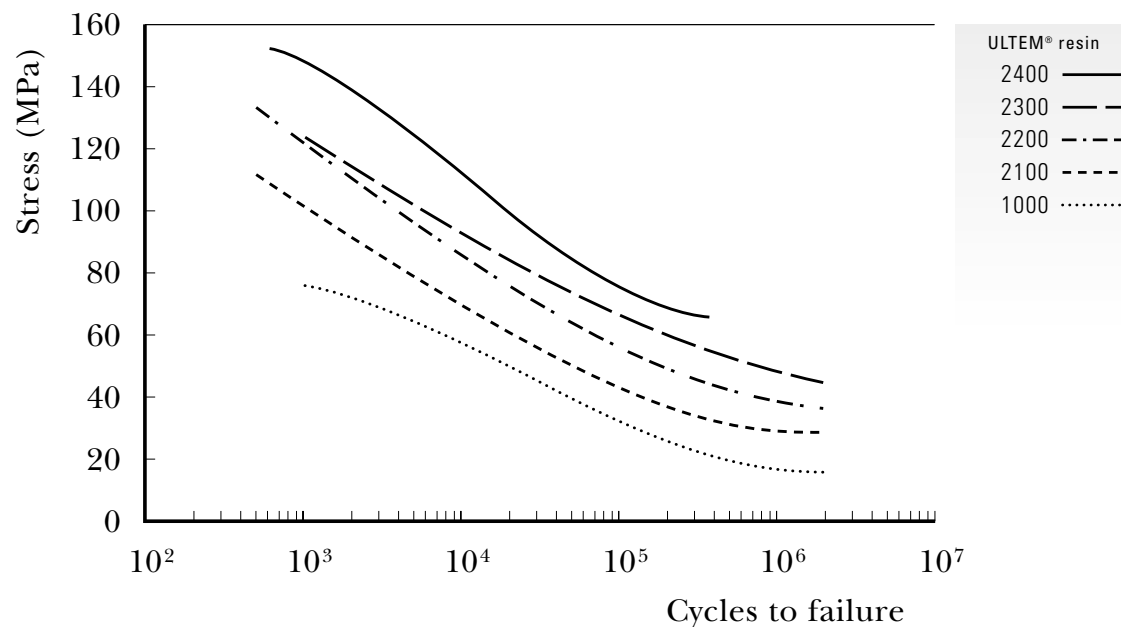

4.4 Electrical Properties

ULTEM® resins exhibit excellent electrical properties which remain stable over a wide range of environmental conditions. This stability, together with outstanding thermal and mechanical properties, make ULTEM® resins ideal candidates for highly demanding electrical and electronic applications.

Relative permittivity

Although either low or high absolute values of the relative permittivity may be desirable depending upon the application, it is more important that the values remain stable over the entire service temperature and/or frequency range. ■ FIGURES 4-11 and 4-12 demonstrate the stability of ULTEM® 1000 resin over varying temperatures and frequencies.

■ FIGURE 4-11

Relative permittivity of ULTEM® 1000 resin vs. temperature at 50% RH

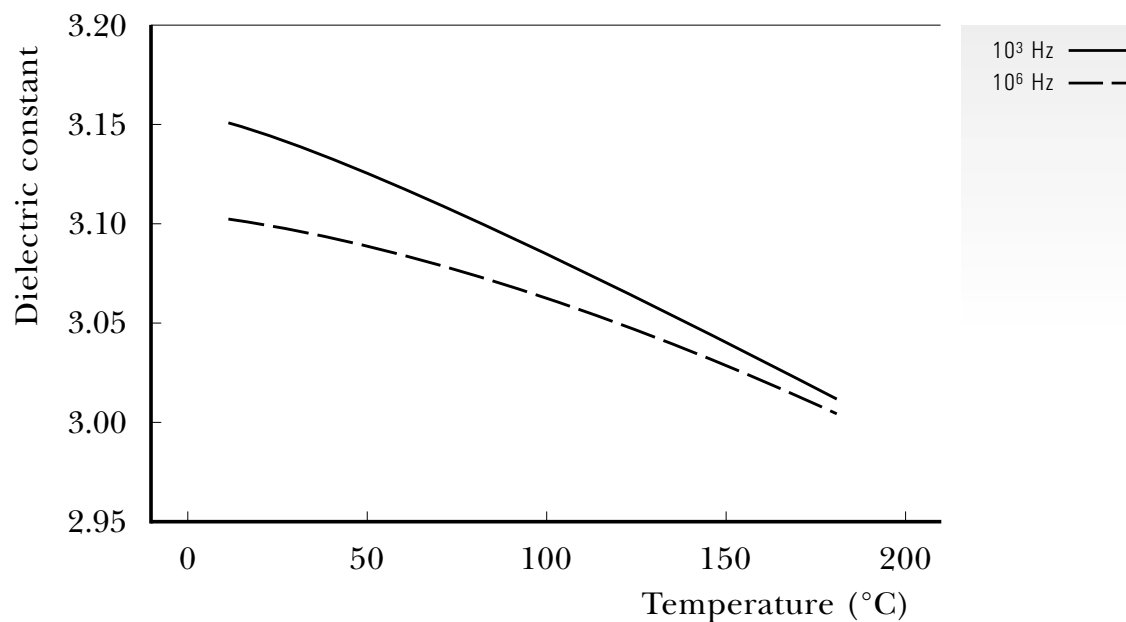

■ FIGURE 4-12

Relative permittivity of ULTEM® 1000 resin vs. frequency at 50% RH

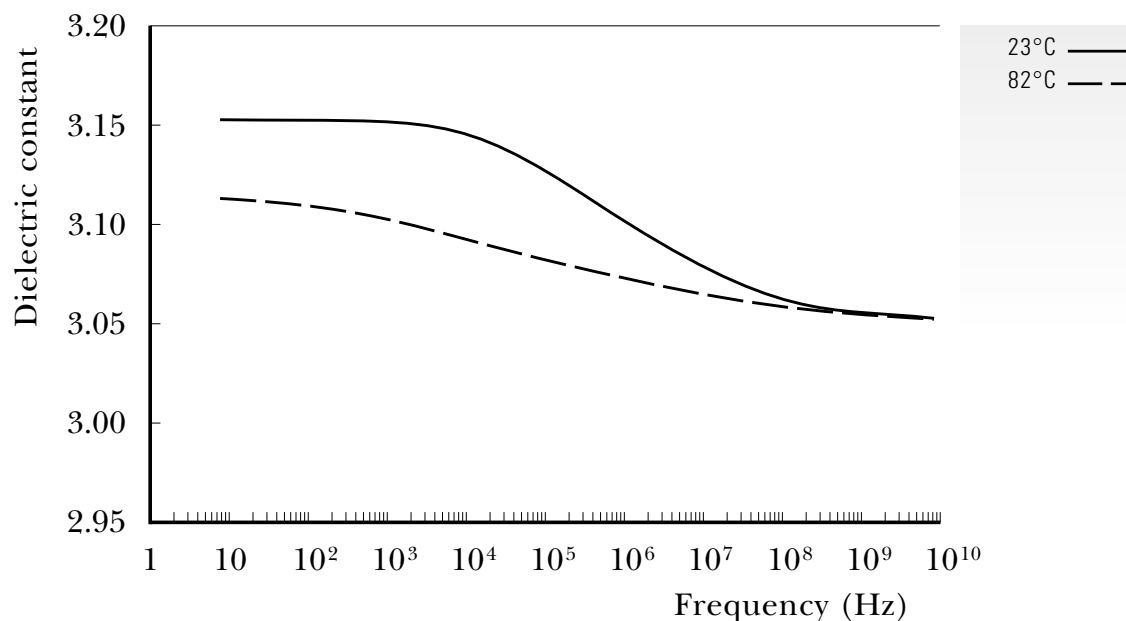

Dissipation factor

As shown in ■ FIGURE 4-13, ULTEM® 1000 resin exhibits an exceptionally low dissipation factor over a wide range of frequencies, particularly in the kilohertz (10^3 Hz) and gigahertz (10^9 Hz) ranges. In addition, this low dissipation factor remains

■ FIGURE 4-13

Dissipation factor of ULTEM® 1000 resin vs. frequency at 50% RH

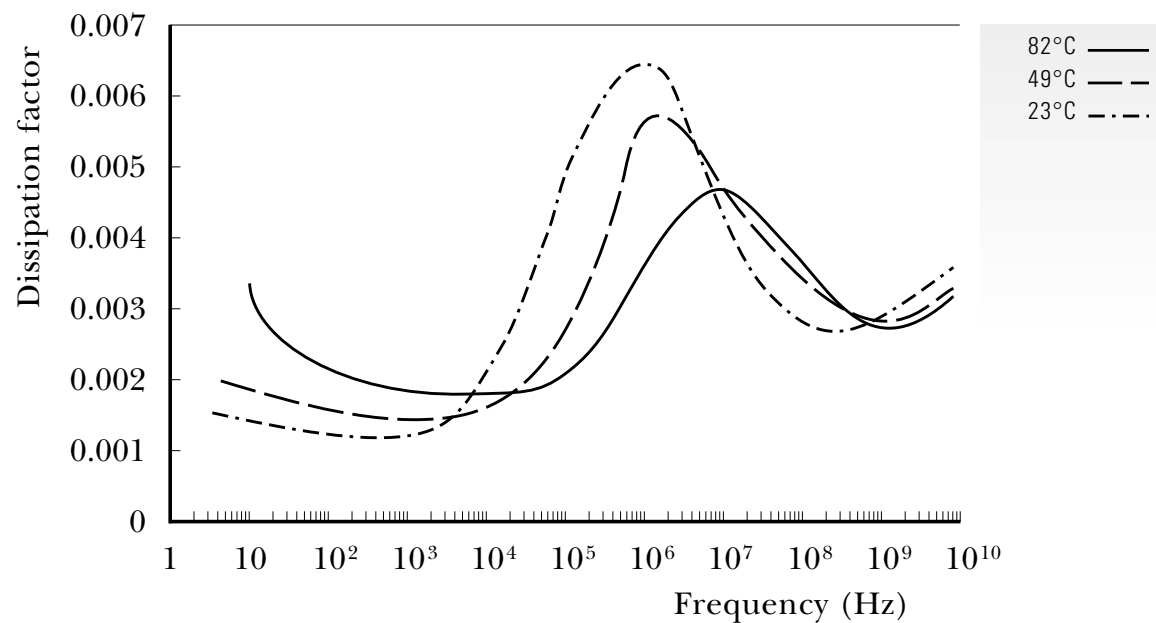

constant over the resin's entire useful temperature range. This behavior is of prime importance in applications such as computer circuitry and microwave components where the resin provides a minimum loss of electrical energy in the form of heat.

■ FIGURES 4-14 and 4-15 demonstrate the superior performance of ULTEM® PEI resin over other thermoplastic resins traditionally considered for these electrotechnical applications. The dissipation factor peak around megahertz (10⁶ Hz) is caused by moisture in the material and therefore depends on the ambient conditions.

■ FIGURE 4-14

Dissipation factor vs. frequency at 23°C, 50% RH

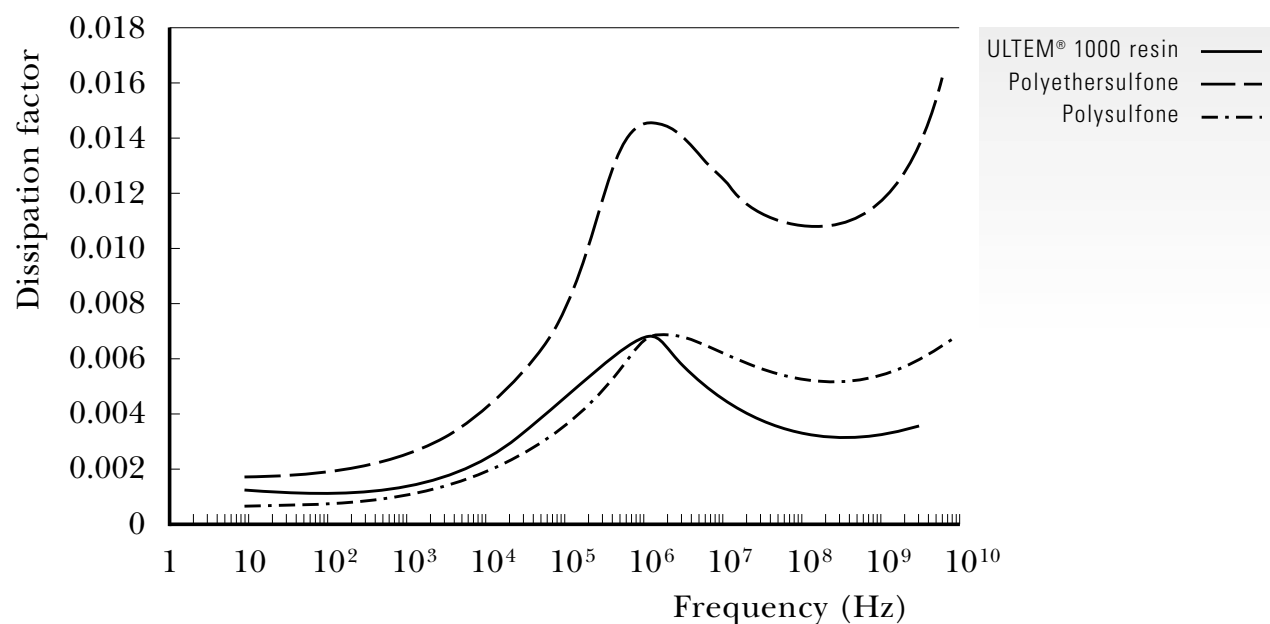

■ **FIGURE 4-15**
Dissipation factor
vs. temperature
at 2.45×10^9 Hz

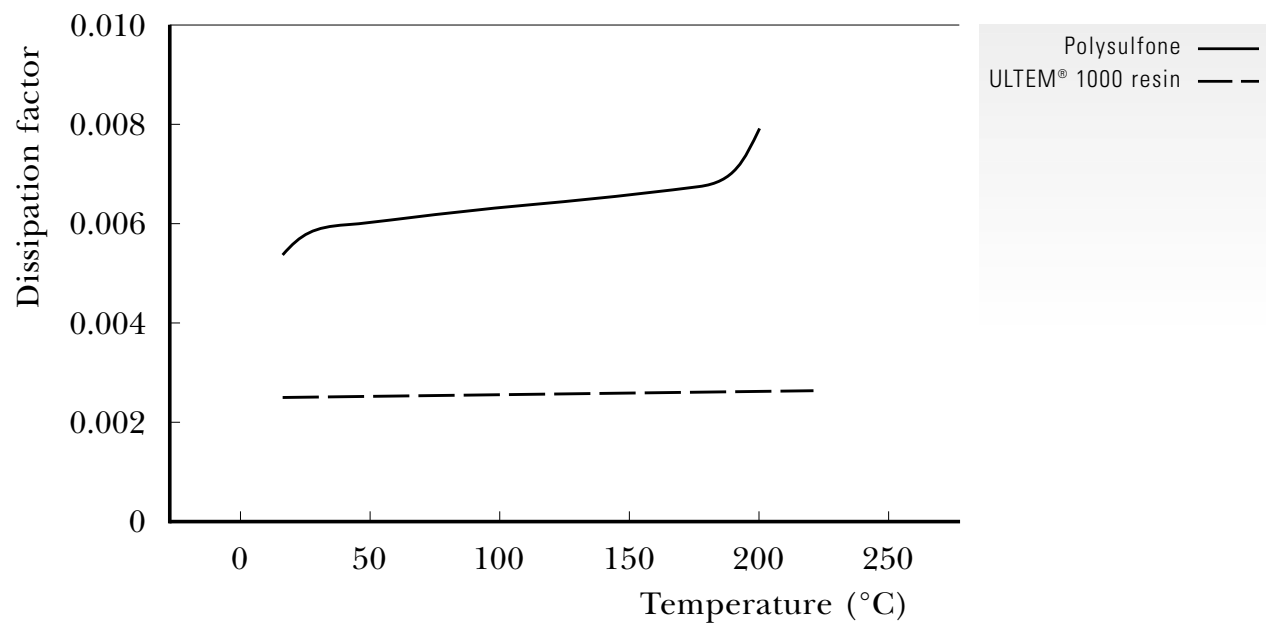

Dielectric strength

An excellent electrical insulator, ULTEM® resin exhibits a dielectric strength of 25 kV/mm at 1.6 mm (in oil). The effect of thickness on dielectric strength for ULTEM® 1000 resin is shown in ■ FIGURE 4-16.

■ **FIGURE 4-16**
Dielectric strength
of ULTEM® 1000 resin
as a function of
thickness

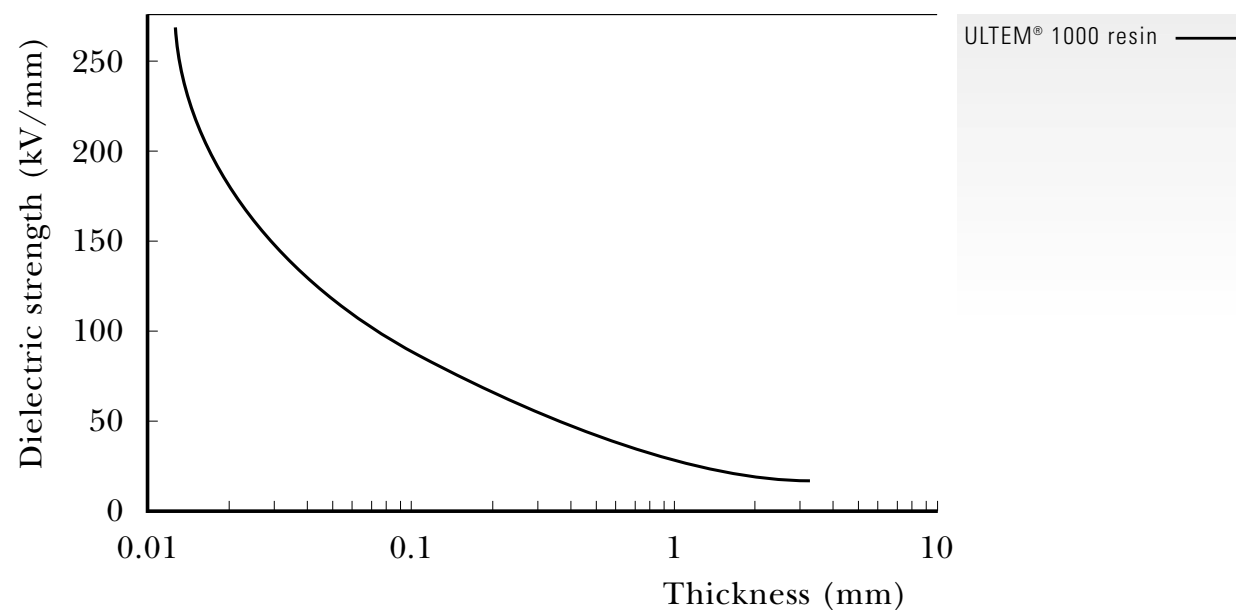

4.5 Environmental Resistance

Chemical resistance

Unlike other amorphous resins, ULTEM® polyetherimide resin demonstrates unusually good resistance to a wide range of chemicals.

■ TABLE 4-3 lists the performance of ULTEM® 1000 and CRS 5000 resin series in a variety of common environments at several stress levels.

In applications requiring prolonged immersion, finished part performance should always be evaluated on the actual part under actual service conditions.

ULTEM® resin displays excellent property retention and resistance to environmental stress cracking when exposed to most commercial automotive and aircraft fluids, fully halogenated hydrocarbons, alcohols and weak aqueous solutions. Exposure to partially halogenated hydrocarbons and strong alkaline environments should be avoided.

In an effort to further enhance the inherent chemical resistance of ULTEM® resin, a chemical resistant ULTEM® CRS 5000 resin series has been developed. These amorphous materials combine the chemical resistance characteristics often associated with crystalline and specialty materials with the excellent processing characteristics typical of ULTEM® resins.

Cleaning and degreasing

Cleaning or degreasing of ULTEM® resin finished parts can be performed using methyl or isopropyl alcohol, soap solutions, heptane, hexane or naphtha. The parts should not be cleaned with partially halogenated hydrocarbons or with ketones such as MEK or strong bases, such as sodium hydroxide.

■ TABLE 4-3

Chemical compatibility of ULTEM® 1000 resin and ULTEM® CRS 5001 resins

Media	Temp (°C)	Immersion (days)	Strain (%)	ULTEM® CRS 5001 resin	ULTEM® 1000 resin
Alcohols ¹⁾					
Methanol	23	21	0.25	n.a.	n.a.
		21	0.5	n.a.	n.a.
	60	21	0.25	n.a.	n.a.
		21	0.5	n.a.	n.a.
Aqueous Detergents ²⁾ & Cleaners					
Domestic Detergent	23	21	0.25	n.a.	n.a.
		21	0.5	n.a.	n.a.
	60	21	0.25	n.a.	n.a.
		21	0.5	n.a.	n.a.
Bleach (10%)	23	21	0.25	n.a.	n.a.
		21	0.5	n.a.	n.a.
	60	21	0.25	n.a.	n.a.
		21	0.5	n.a.	n.a.

Key to performance

n.a.	no attack
f.	failure / ruptured
c.	crazing
sv.c.	severe crazing
s.c.	slight crazing
–	not tested

¹⁾ Other examples of alcohols include ethyl, propyl and some glycols

²⁾ Other examples of aqueous detergents include hypochlorite bleaches and phosphate cleaners

■ TABLE 4-3 (continued)

Media	Temp (°C)	Immersion (days)	Strain (%)	ULTEM® CRS 5001 resin	ULTEM® 1000 resin
Water					
Steam	100	21	0.25	n.a.	n.a.
		21	0.5	n.a.	f. (216 hrs.)
Distilled Water	23	21	0.25	n.a.	n.a.
		21	0.5	n.a.	n.a.
Chlorinated Solvents ³⁾					
1,1,2 Trichloroethylene	23	2 hrs.	0.25	sv.c.	f.
		2 hrs.	0.5	sv.c.	f.
1,1,1 Trichloroethylene	23	21	0.25	n.a.	n.a.
Chloroform		21	0.5	n.a.	f. (24 hrs.)
Esters					
Dibutylphthalate	23	21	0.25	n.a.	n.a.
		21	0.5	c.	f. (24 hrs.)
	85	21	0.25	n.a.	f.
		24 hrs.	0.5	c.	f.
Aromatic Hydrocarbons ⁴⁾					
Toluene	23	21	0.25	n.a.	f. (48 hrs.)
		48 hrs.	0.5	c.	f. (2 hrs.)
	85		0.25	c. (48 hrs.)	f.
			0.5	c. (48 hrs.)	f.

Key to performance

n.a.	no attack
f.	failure / ruptured
c.	crazing
sv.c.	severe crazing
s.c.	slight crazing
–	not tested

³⁾ Other examples of chlorinated solvents include methylene chloride and ethylene chloride

⁴⁾ Other examples of aromatic hydrocarbons include benzene, xylene and gasoline

Media	Temp (°C)	Immersion (days)	Strain (%)	ULTEM® CRS 5001 resin	ULTEM® 1000 resin
Ketones and Aldehydes ⁵⁾					
Methyl Ethyl Ketone (MEK)	23	21	0.25	n.a.	f. (2 hrs.)
			0.5	c. (48 hrs.)	f. (2 hrs.)
	75		0.25	s.c. (48 hrs.)	f.
			0.5	c. (48 hrs.)	f.
Aircraft Fluids					
Skydrol 500B	23	21	0.25	n.a.	n.a.
Hydraulic Fluid	85	21	0.5	n.a.	f. (72 hrs.)
		21	0.25	n.a.	f.
			0.5	c. (24 hrs.)	f.
Automotive Fluids					
Gasoline	73	21	0.25	n.a.	n.a.
ASTM Fuel C	60	21	0.5	n.a.	n.a.
		21	0.25	n.a.	n.a.
		21	0.5	n.a.	f.
Diesel Fuel	23	5	0.25	–	n.a.
			0.5	–	n.a.
Brake Fluid	23	21	0.25	n.a.	n.a.
			0.5	n.a.	n.a.
	85	21	0.25	n.a.	f. (168 hrs.)
			0.5	f.	f.

Key to performance

n.a.	no attack
f.	failure / ruptured
c.	crazing
sv.c.	severe crazing
s.c.	slight crazing
–	not tested

⁵⁾ Other examples of ketones and aldehydes include acetone, acetaldehyde and formaldehyde

■ TABLE 4-3 (continued)

Media	Temp (°C)	Immersion (days)	Strain (%)	ULTEM® CRS 5001 resin	ULTEM® 1000 resin
Automotive Fluids					
Transmission Fluid	23	5	0.25	–	n.a.
			0.5	–	n.a.
	120	7	0.25	–	n.a.
			0.5	–	n.a.
Antifreeze (75%)	23	21	0.25	n.a.	n.a.
			0.5	n.a.	n.a.
	150	21	0.25	n.a.	f.
			0.5	f. (72 hrs.)	f.
Mineral Oil	23	21	0.25	n.a.	n.a.
			0.5	n.a.	n.a.
	140	21	0.25	n.a.	f. (168 hrs.)
			0.5	n.a.	f. (168 hrs.)
Acids ⁶⁾					
Sulphuric Acid (37%) Inorganic	23	21	0.25	n.a.	n.a.
			0.5	n.a.	n.a.
	90	21	0.25	n.a.	n.a.
			0.5	n.a.	n.a.

Key to performance

n.a. no attack
 f. failure / ruptured
 c. crazing
 sv.c. severe crazing
 s.c. slight crazing
 – not tested

⁶⁾ Other examples of acids include hydrochloric, phosphoric and glacial acetic

Media	Temp (°C)	Immersion (days)	Strain (%)	ULTEM® CRS 5001 resin	ULTEM® 1000 resin
Acids ⁶⁾					
Acetic Acid (20%) Organic	23	21	0.25	n.a.	n.a.
			0.5	n.a.	n.a.
	90	21	0.25	n.a.	n.a.
			0.5	n.a.	n.a.
Strong Bases ⁷⁾					
Sodium Hydroxide (30%)	23	21	0.25	n.a.	n.a.
			0.5	n.a.	n.a.
	90	21	0.25	f.	f.
			0.5	f.	f.
Weak Bases ⁸⁾					
Ammonium Hydroxide (10%)	23	21	0.25	n.a.	n.a.
			0.5	n.a.	n.a.
	90	21	0.25	f.	f.
			0.5	f.	f.

Key to performance

n.a. no attack
 f. failure / ruptured
 c. crazing
 sv.c. severe crazing
 s.c. slight crazing
 – not tested

⁶⁾ Other examples of acids include hydrochloric, phosphoric and glacial acetic

⁷⁾ Other examples of strong bases include other metal hydroxides and some amines

⁸⁾ Other examples of weak bases include dilute forms of metal hydroxides and some amines

Aqueous solutions

ULTEM® resin is resistant to mineral acids, mineral salt solutions and dilute bases (pH less than 9) as shown in ■ TABLE 4-4. This property, together with high temperature performance and transparency, qualifies the resin for applications such as laboratory ware and automotive heat transfer systems.

Chemical (concentration)	% Retention of Tensile Stress	% Weight Gain
Deionized water	94	1.25
Zinc chloride (10%)	96	1.13
Potassium carbonate (30%)	97	0.85
Tin chloride (10%)	97	1.05
Citric acid (40%)	96	1.06
Hydrochloric acid (20%)	99	0.61
Phosphoric acid (20%)	97	0.99
Sulphuric acid (20%)	97	0.89
Chromic acid (15%)	94	0.73
Formic acid (10%)	94	1.29
Nitric acid (20%)	96	1.07
Acetic acid (20%)	95	1.15
Potassium hydroxide (10%)	97	1.55
Ammonium hydroxide (10%)	68	1.79
Sodium hydroxide (10%)	97	1.00
Cyclohexylamine (1%)	97	1.10

■ TABLE 4-4

Chemical Resistance of ULTEM® 1000 resin to Aqueous Solutions at 23°C, no stress applied (100 day immersion)

Hydrolytic stability

■ FIGURE 4-17 depicts the excellent tensile stress retention of ULTEM® 1000 resin after 10,000 hours of immersion in water at 100°C. In addition, tests show that ULTEM® resin's physical properties remain virtually unchanged after repeated cycling from steam pressure to drying in vacuum at room temperature. Therefore ULTEM® resin is a very good material for repeated autoclavability.

Ultraviolet exposure

ULTEM® resin is resistant to UV radiation without the addition of stabilizers. Properties like tensile stress, modulus and Izod notched impact show a negligible change after long-term exposure to UV. However, care should be taken, since color changes and loss of Izod unnotched impact performance might occur after long-term exposure.

■ FIGURE 4-17

Effect of water exposure on tensile stress of ULTEM® 1000 resin

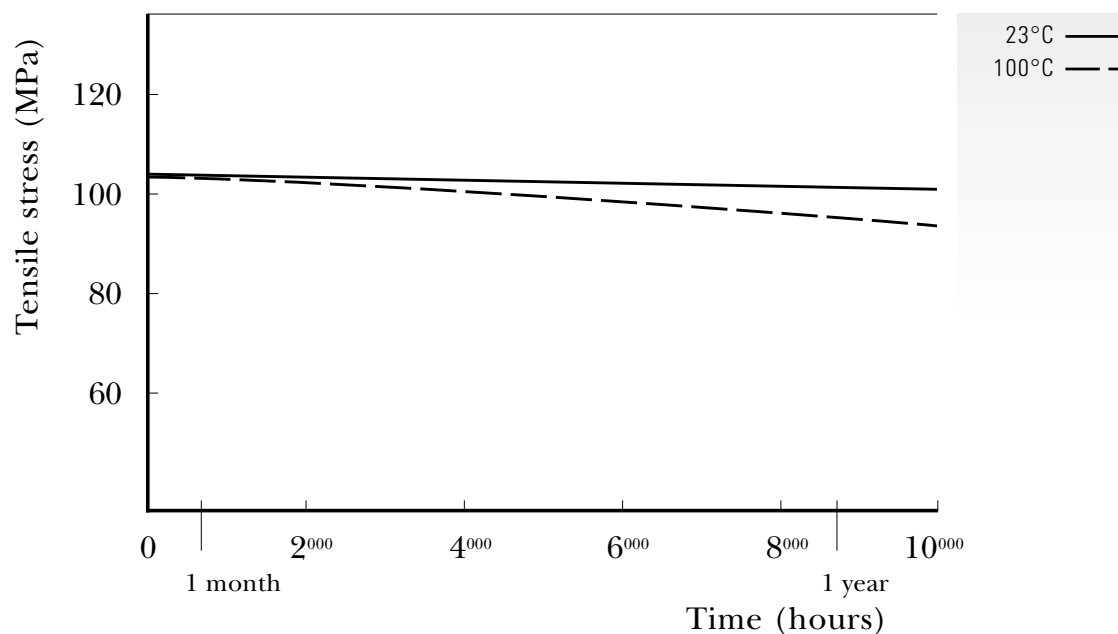

Radiation resistance

Parts molded in ULTEM[®] resin demonstrate excellent resistance to gamma radiation, as shown in ■ FIGURE 4-18. A loss of less than 6% tensile strain (ISO 527) was observed after cumulative exposure to 500 megarads at the rate of one megarad per hour using Cobalt 60.

■ FIGURE 4-18

Effect of gamma radiation exposure on tensile properties of ULTEM[®] 1000 resin

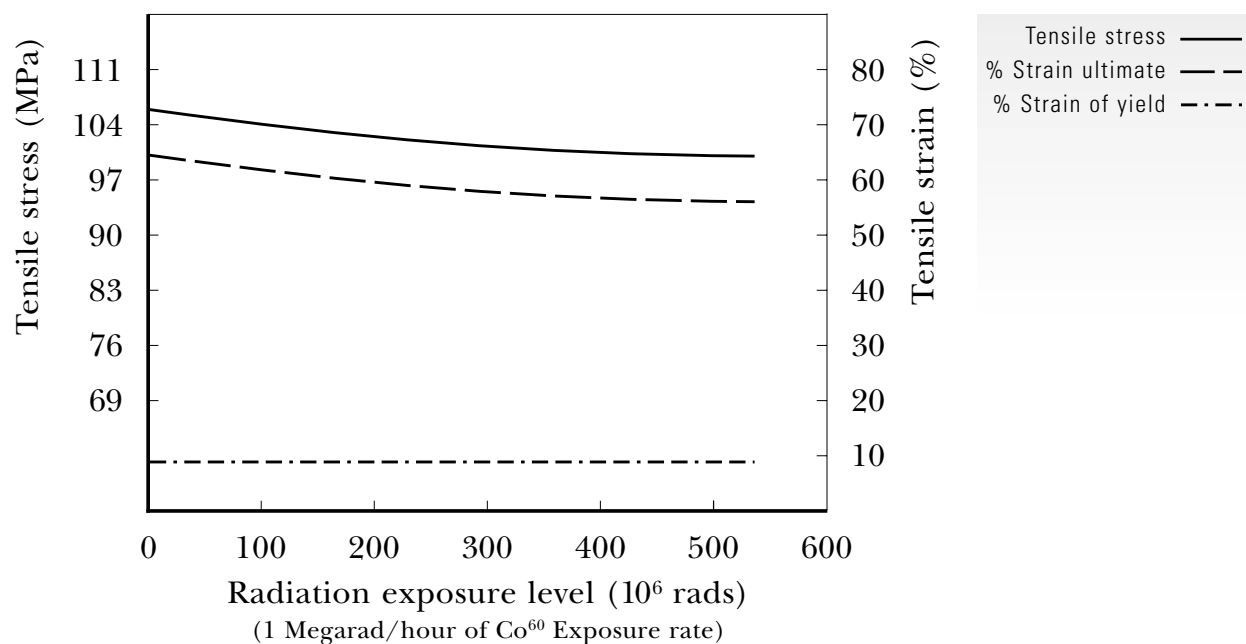

Agency recognition

ULTEM[®] resins have been tested and comply with a number of agency regulations and specifications.

ULTEM[®] resins' heat stability and flammability characteristics make them excellent choices for numerous applications which require Underwriters Laboratory, UL, approval. Several grades of ULTEM[®] resin are also recognized by, or otherwise comply with, regulations such as FDA, EU, USP, DIN, VDE, FAR, ABD and military regulations.

5 Design*

To extract the maximum performance from ULTEM® resin, the designer should strive to take full advantage of the excellent physical properties of the material as well as the design freedom offered by the injection molding process.

The designer should minimize molded-in stress in applications made from ULTEM® resin because the higher the stress level in a finished part, the more susceptible it is to chemical attack.

Molded-in stress in parts can be minimized by:

- Avoiding thin walls and sharp corners
- Avoiding large and sharp transitions in wall thickness
- Ensuring balanced and uniform part filling
- Properly designing ribs and coring to increase stiffness without increasing wall thickness

ULTEM® resin can be ideally suited to the design of long-term high temperature and mechanically stressed applications as confirmed by the uniaxial fatigue diagram in ■ FIGURE 4-10 on page 23 of this brochure.

* In all cases extensive testing of the application under the working conditions is strongly recommended. The actual performance and interpreting of the results of end-use testing are the end-producer's responsibility.

The most important material property to be able to design for stiffness and strength is the stress-strain curve of the material.

In ■ FIGURE 5-1, the curves of unreinforced ULTEM® 1000 base polymer and reinforced ULTEM® 2100, 2200, 2300, 2400 and 7801 resins are depicted.

Note

General information on designing with engineering thermoplastics can be found in the GE Plastics “Design Guide.”

■ FIGURE 5-1
Stress-strain curve
(23°C)

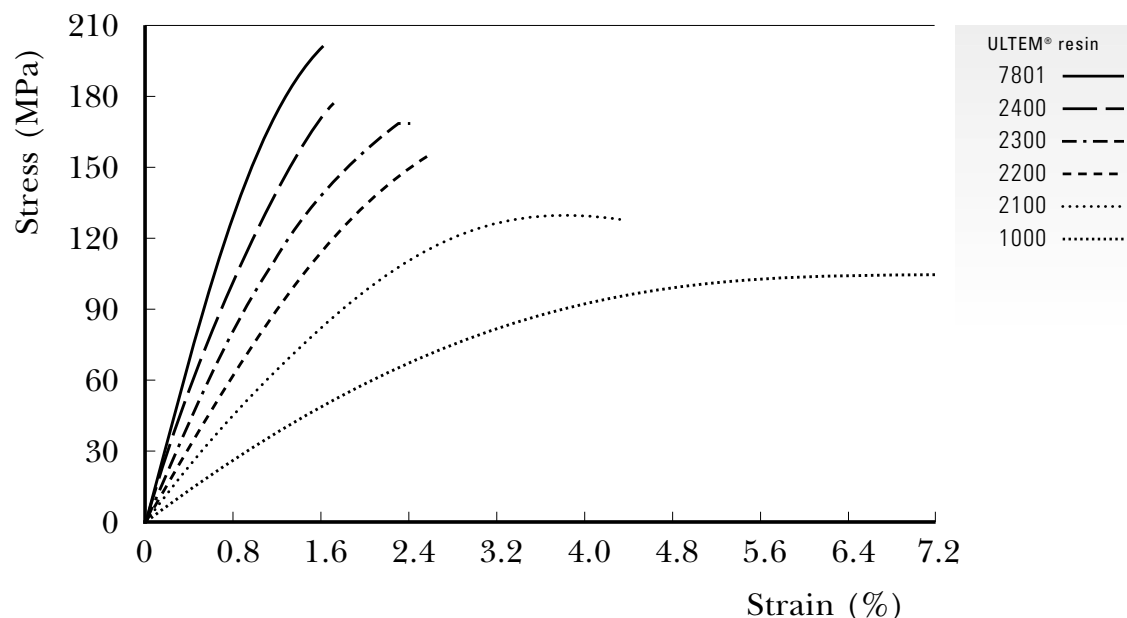

6 Processing

6.1 Materials

An amorphous thermoplastic polyetherimide, ULTEM® resin combines high performance with good processing characteristics. It offers a combination of high heat resistance with high strength, modulus and broad chemical resistance.

ULTEM® resins are inherently flame resistant with low smoke emission. Some grades have a UL 94 V-0 rating* at a thickness of 0.25 mm. Other grades display a high dielectric constant and a high dissipation factor over a wide range of temperatures and frequencies.

ULTEM® resin is a high performance amorphous engineering thermoplastic. ■ TABLE 6-1 shows the basic ULTEM® resin families.

■ TABLE 6-1

The basic ULTEM® resin families include the following:

Property	Characteristics	Typical Designations
Unreinforced	Resin grades offering outstanding mechanical, thermal and environmental resistance properties.	1000 series
Glass Reinforced (10% to 30% GF)	Resin grades offering increased strength and stiffness. Low warpage grades are also available.	2000 series
Wear Resistant	Resin grades with low coefficients of friction designed for gears, bearings and other sliding surface contact applications.	4000 series
Chemical Resistance	Resins that offer resistance to strong acids and bases, aromatics and ketones. Also heat resistance.	5000 series
Higher Heat	Resins designed specifically for high heat aircraft interior applications requiring thermal dimensional stability.	6000 series
High Strength	Resin grades offering outstanding stiffness and strength.	7000 series
Hydrolytic Stability	Heat blended resin grades offering impact strength, stain resistance. Suitable for food service and automotive application environments.	ATX series

6.2 Mold Design

Shrinkage

ULTEM® resins, being amorphous, exhibit relatively predictable, repeatable shrink rates. ULTEM® 1000 resin shrinks isotropically; shrinkage becomes anisotropic when the resin is reinforced.

Part design, gate location and processing conditions will all influence shrinkage.

- A decrease in mold temperature can be expected to produce a corresponding decrease in mold shrinkage. It should be noted that if a part is molded at low mold temperatures [i.e., 100°F (38°C)] and later exposed to higher than ambient temperatures [i.e., 150°F (66°C)] some additional post-mold shrinkage may occur.
- An increase in injection pressure will produce a decrease in mold shrinkage. A part that is not completely packed will typically experience excessively high mold shrinkage.
- Lowering the melt temperatures will produce a slight decrease in mold shrinkage.
 - FIGURES 6-1 through 6-3 show the effect of various factors on the shrink rate of ULTEM® resin.

■ TABLE 6-2 shows typical shrinkage for various grades of ULTEM® resin at 0.125" wall thicknesses. By referring to these figures designers can predict a more accurate shrink rate for a specific part geometry. End-use environmental testing of finished parts, however, should be used to provide the most reliable data.

■ TABLE 6-2

Nominal shrink rate, in/in @ 0.125" wall thickness.

ULTEM® Resin Grade	Parallel to Flow*	Perpendicular to Flow*
1000	0.007	0.007
2100	0.005	0.006
2200	0.003	0.005
2300	0.002	0.004
2400	0.001	0.003
4000	0.003	0.005
4001	0.006	0.007

*Median values

■ FIGURE 6-1

Effect of injection pressure on shrinkage of ULTEM® 1000 resin.*

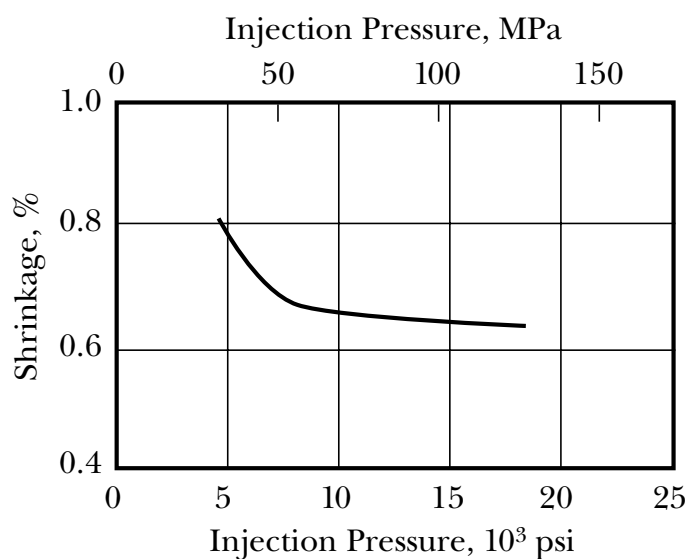

■ FIGURE 6-2

Effect of injection rate on shrinkage of ULTEM® 1000 resin.*

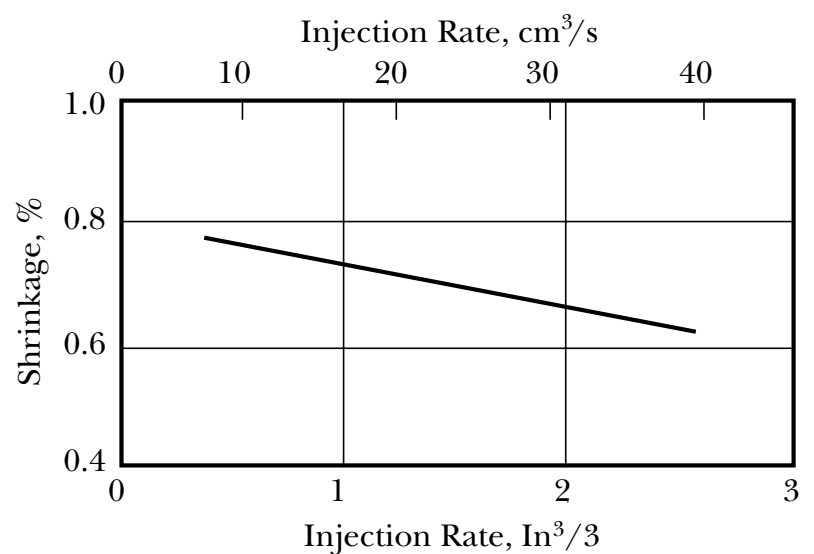

■ FIGURE 6-3

Effect of wall thickness on shrinkage of ULTEM® 1000 resin.*

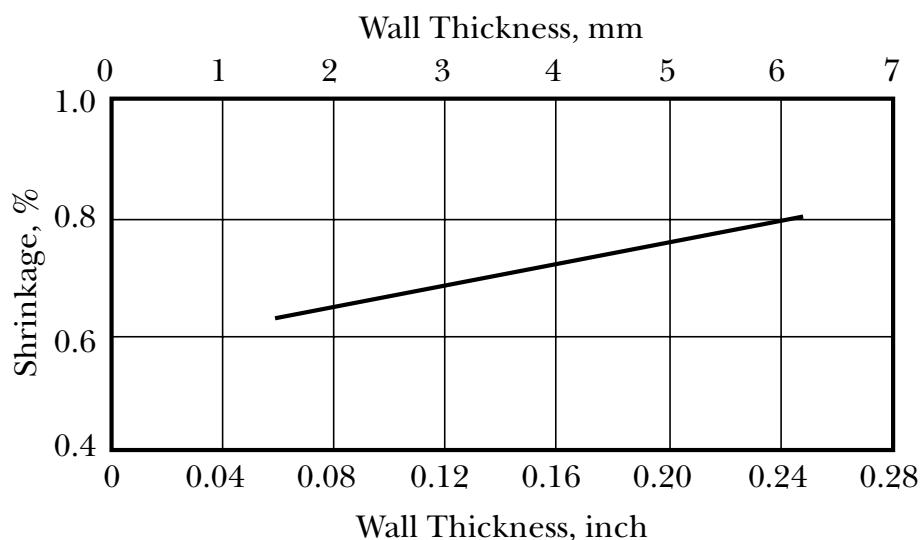

* These curves represent shrinkage that can be expected when processing engineering thermoplastic resins at the standard conditions recommended in this guide. Varying processing conditions can affect shrinkage. Prototype tests in part geometry will provide the most reliable data.

6.3 Equipment

Machine Selection

ULTEM® resins can be molded in most standard injection molding machines. Reciprocating screw machines are suggested.

When determining the size of equipment to be used for molding a particular ULTEM® resin part, total shot weight and total projected area are the two basic factors to be considered.

Optimum results are generally obtained when the total shot weight (all cavities plus runners and sprues) is equal to 30 to 80% of the machine capacity. Very small shots in a large barrel machine may create unnecessarily long resin residence times. If it is necessary to mold at the

high end of the temperature range, reduced residence time is usually required to reduce the possibility of material heat degradation. Therefore, for higher temperature molding requirements, it is suggested that the minimum shot size be greater than 60% of the machine capacity.

Once the total projected area of the complete shot (all cavity and runner areas subjected to injection pressure) has been determined, 4 to 6 tons of clamp force should be provided for each square inch of projected area to reduce flashing of the part. Glass reinforced resins may require slightly higher clamp force (estimate one ton per square inch more). Wall thickness, flow length and molding conditions will determine the actual tonnage required (■ FIGURE 6-4).

■ FIGURE 6-4

Clamping force for ULTEM® resins.

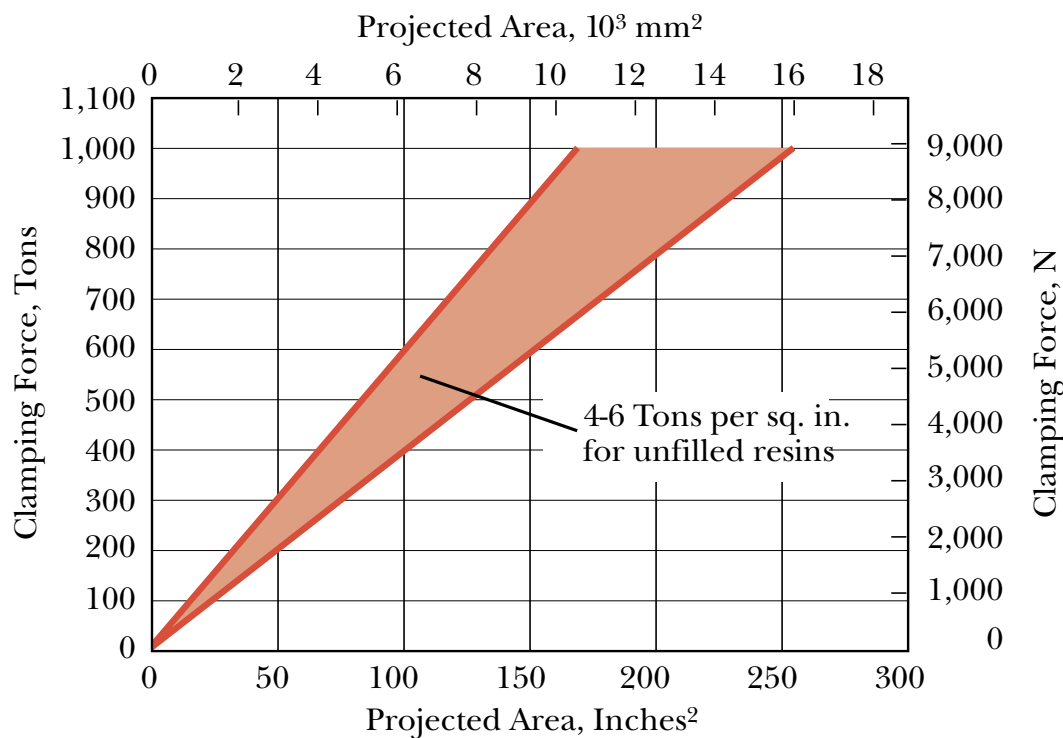

Barrel Selection and Screw Design Considerations

Conventional materials of construction for compatible screws and barrels are generally acceptable for processing ULTEM® resins. The use of bimetallic barrels is suggested.

Depending on screw diameter, a compression ratio of about 2.2:1 with a length to diameter ratio of 20:1 is preferred. A short feed zone (5 flights) and a long compression zone (11 flights) with a gradual constant taper leading to a short metering zone (4 flights) is also suggested. The compression should be accomplished over a gradual and constant taper since sharp transitions can result in excessive shear and material degradation. If specific screw selection is not possible, general purpose screws with length to diameter ratios from 16:1 through 24:1 and compression ratios from 1.5:1 to 3.0:1 have been used successfully. Vented barrels are not suggested for processing ULTEM® resins.

The non-return valve should be of the sliding check ring type. Flow-through clearances of at least 80% of the cross-section of the flow area in the metering zone of the screw are usually necessary.

Drying Parameters

ULTEM® resin, like most thermoplastics, absorbs atmospheric moisture which can cause degradation of the polymer during processing. Moisture content higher than 0.02% can be expected to cause appearance issues, brittle parts and an increase in the melt flow of the material (■ FIGURE 6-5). The suggested moisture level can usually be reached by predrying ULTEM® resin at temperatures suggested in ■ TABLE 6-3.

■ TABLE 6-3

ULTEM® resin drying suggestions.

ULTEM Resin Grades	Drying Temp. (°F)	Drying Time* (Hrs.)
Unreinforced	300	4
Reinforced	300	6
Blended	275	6

*Times suggested are “mean times” and may be longer for some colors and grades. Moisture content should be 0.2% or less.

■ FIGURE 6-5

Moisture absorption of ULTEM® 1000 resin vs. relative humidity at 24 hours.

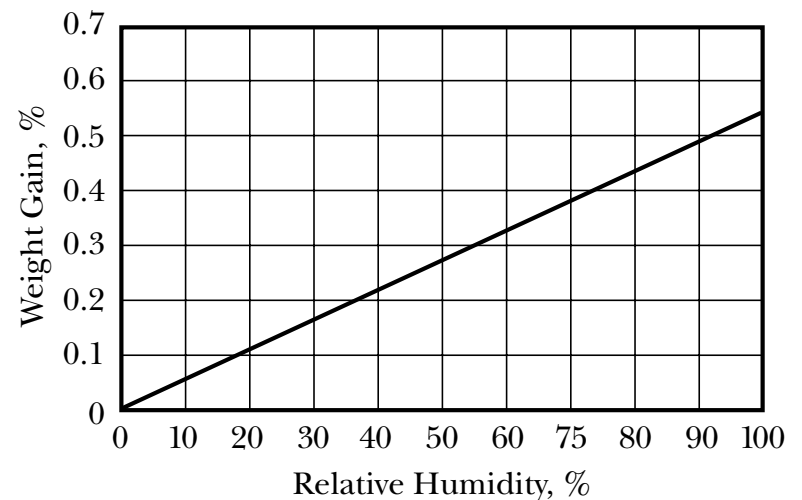

Drying Equipment

To avoid cross contamination, the dryers and material transfer system must be clean.

A closed loop, dehumidifying, recirculating hot air hopper dryer with an after-cooler is suggested for ULTEM® drying resins (■ FIGURE 6-6). The after-cooler is especially important to maintain the drying efficiency of the desiccant cartridge. This system utilizes rechargeable desiccant cartridges to provide dry air. A correctly designed dryer and hopper provide a steady flow of dry pellets to the intake of the molding machine.

The required drying temperature should be monitored at the input of the hopper. The dew point of the air at the input of the hopper should be -20°F (-29°C) to -40°F (-40°C) or lower.

■ FIGURE 6-6

Schematic of a typical desiccant dryer.

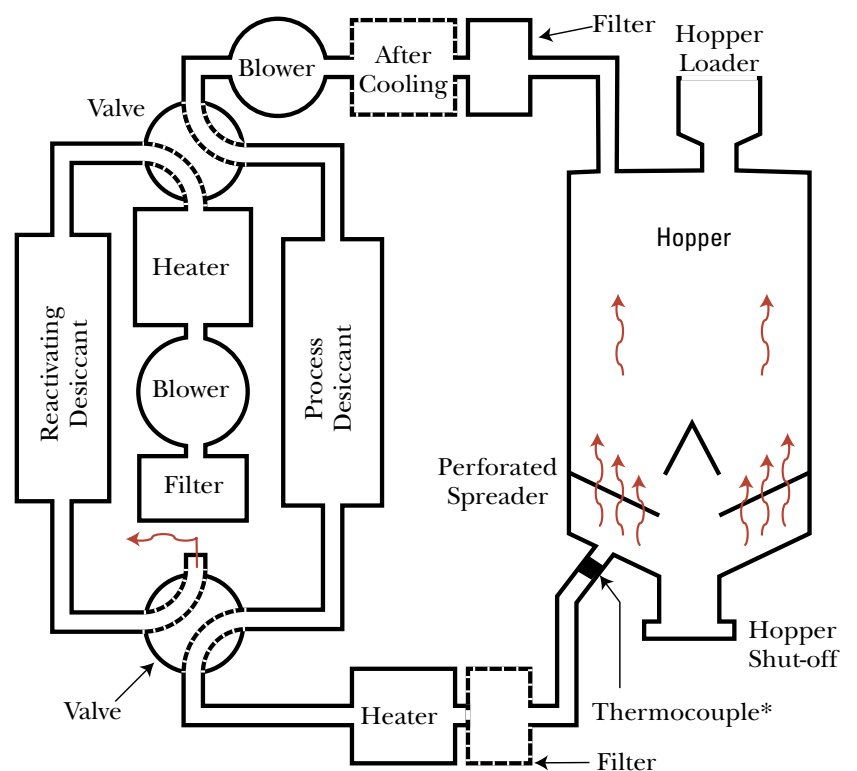

*Monitors air temperature, dew point and air flow at this location.

6.4 Molding Conditions

ULTEM® resin has very good moldability due to its good flow characteristics. It is a good choice for consideration in complex and multi-cavity tools and depending on flow length, can be molded in wall sections as thin as 10 mils (0.25 mm). Since ULTEM® resin has a wide processing latitude, the following conditions are typical settings which can be used as guidelines in machine setup.

Melt Temperature

Because of the good thermal stability of ULTEM® resin, melt temperatures ranging from 640 to 750°F (338 to 399°C) are common. A melt temperature of 675 to 725°F (357 to 385°C) is typical for most applications. Temperatures over 720°F (382°C) may result in a color shift due to the inability of pigments in some colors to handle higher temperatures. ULTEM® ATX resin grades should be processed at lower temperatures, typically ranging from 590 to 700°F (310 to 371°C).

Mold Temperature

ULTEM® resin should always be molded in temperature-controlled molds. Mold temperatures, as measured by a surface pyrometer, should range from 225 to 350°F (107 to 177°C). However, ULTEM® ATX resin grades should only be molded at mold temperatures up to 300°F (149°C). Exceeding this mold temperature could result in splay. For enhanced properties and cycle time, a temperature of 200°F (93°C) is a good choice for most ULTEM® resin parts (■ TABLE 6-4). End-use testing of finished parts can confirm whether this temperature is appropriate for a particular application.

The midpoint of the suggested range will generally give good results with respect to part appearance and cycle time. Higher mold temperatures can be used for increased flow, improved knit-line strength, and maximum effective heat and chemical resistance through the reduction of molded-in stresses. Using lower than the suggested mold temperatures can result in high molded-in stresses and may compromise part integrity. The use of insulator sheets to separate the mold base from the machine platens is strongly suggested.

■ TABLE 6-4

Typical Processing Parameters
Typical Injection Molding
Molding Conditions

Processing Parameters	Units	1000	2300	4000	ATX100		
		1010 2100 2110 2200 2210 2212 (min.)	2310 2312 2400 2410 3451 (max.)	4001 8015 9075 9076 ATX200 (min.) (max.)	(min.)	(max.)	
Drying Temperature	°F (°C)	—	300 (149)	—	275 (135)	—	275 (135)
Drying Time (Normal)	h	4	6	4	6	4	6
Drying Time (Max.)	h	—	24	—	10	—	12
Maximum Moisture	%	—	0.02	—	0.02	—	0.02
Melt Temperature	°F (°C)	660 (348)	750 (398)	660 (348)	700 (371)	630 (332)	670 (354)
Nozzle	°F (°C)	650 (343)	750 (398)	660 (348)	700 (371)	620 (326)	660 (348)
Front Zone	°F (°C)	650 (343)	750 (398)	660 (348)	700 (371)	630 (332)	670 (354)
Middle Zone	°F (°C)	640 (337)	750 (398)	650 (343)	690 (365)	610 (321)	650 (343)
Rear Zone	°F (°C)	630 (332)	750 (398)	640 (337)	680 (360)	590 (310)	630 (332)
Mold Temperature	°F (°C)	275 (135)	325 (163)	275 (135)	325 (163)	200 (93)	275 (135)
Back Pressure	psig (MPa)	50 (0.3)	100 (0.7)	50 (0.3)	100 (0.7)	50 (0.3)	100 (0.7)
Screw Speed	rpm	40	70	40	70	40	70
Shot to Cylinder Size	%	40	60	40	60	40	60
Clamp Tonnage	tons/in ²	3	5	3	5	3	5
Vent Depth	inch	0.0010	0.0030	0.0010	0.0030	0.0010	0.0030

Processing Parameters	Units	AR9100	AR9200	AR9300	7201	7801	
		CRS5001	CRS5011	CRS5111	CRS5211	CRS5311	(min.)
Drying Temperature	°F (°C)	—	300 (149)	—	300 (148)	—	300 (148)
Drying Time (Normal)	h	4	6	4	6	4	6
Drying Time (Max.)	h	—	24	—	24	—	24
Maximum Moisture	%	—	0.02	—	0.02	—	0.02
Melt Temperature	°F (°C)	690 (366)	730 (387)	720 (382)	800 (426)	—	800 (426)
Nozzle	°F (°C)	680 (360)	720 (382)	710 (376)	790 (421)	—	790 (421)
Front Zone	°F (°C)	690 (365)	730 (387)	720 (382)	800 (426)	—	800 (426)
Middle Zone	°F (°C)	670 (354)	710 (376)	700 (371)	790 (421)	—	790 (421)
Rear Zone	°F (°C)	650 (343)	690 (365)	680 (360)	760 (404)	—	760 (404)
Mold Temperature	°F (°C)	275 (135)	325 (162)	275 (135)	325 (162)	—	325 (162)
Back Pressure	psig (MPa)	50 (0.3)	100 (0.7)	50 (0.3)	100 (0.7)	—	100 (0.7)
Screw Speed	rpm	40	70	40	70	—	70
Shot to Cylinder Size	%	40	60	40	60	—	60
Clamp Tonnage	tons/in ²	3	5	3	5	—	5
Vent Depth	inch	0.0010	0.0030	0.0010	0.0030	—	0.0030

Screw Speed

Screw speeds should be adjusted to permit screw rotation during the entire cooling cycle without delaying the overall cycle (■ FIGURE 6-7). Low screw speeds will help reduce glass fiber damage during plastification when molding reinforced grades. Low screw speeds are suggested for ULTEM® ATX resin grades.

Back Pressure

A back pressure of 50 to 100 psi (0.35 to 0.7 MPa) is suggested to promote a homogeneous melt and consistent shot size. Higher back pressures used to improve melt mixing result in higher melt temperatures which could cause material degradation and splay. When molding reinforced grades, low back pressure will generally help reduce glass fiber damage during plastification. Decompression and suckback should be minimized to prevent molded part surface appearance issues such as silver streaks and splay.

Shot Size

The suggested shot size is 30 to 80% of capacity. For blended grades where color control is critical, it is suggested the shot size be as close to 80% of the barrel capacity as possible in order to reduce residence times.

■ FIGURE 6-7

Screw speed suggestions for ULTEM® resins.

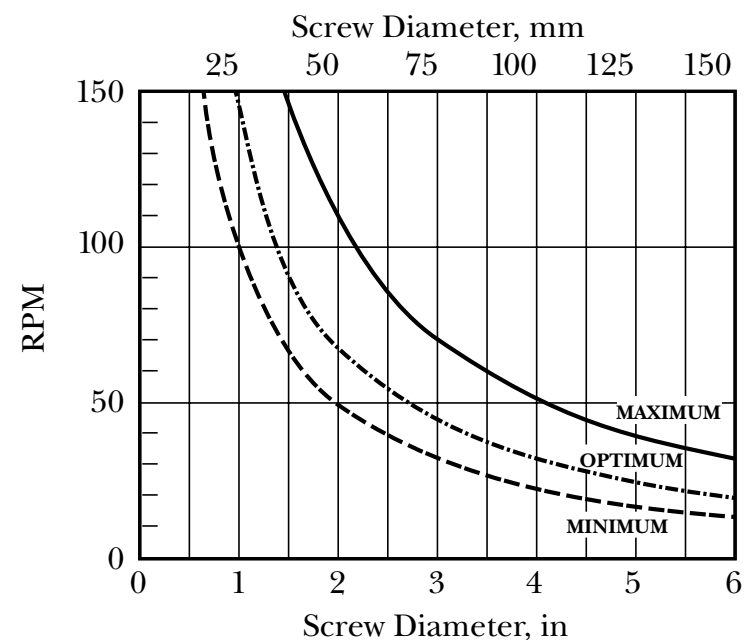

Ram Speed

The fastest fill speed possible generally provides longer flow, fills thinner wall sections and creates better surface finish. Slower fill is suggested for sprue gated and edge-gated parts to reduce splay and jetting. In thick parts, slow fill can help reduce sinks and voids. For ULTEM® resin blends, use the slowest practical injection speed to help minimize shear rate at gate areas.

Programmed injection is suggested for parts with small gates (pin gates and subgates). A slow injection rate can be used at the start to reduce gate blush, jetting and burning of the material.

Injection Pressure

The actual injection pressure will depend on variables such as melt temperature, mold temperature, part geometry, wall thickness, flow length, and other mold and equipment considerations. Generally, the lowest pressures which provide the desired properties, appearance and molding cycle are preferred (■ FIGURE 6-8).

■ FIGURE 6-8

Typical injection pressures for ULTEM® resins.

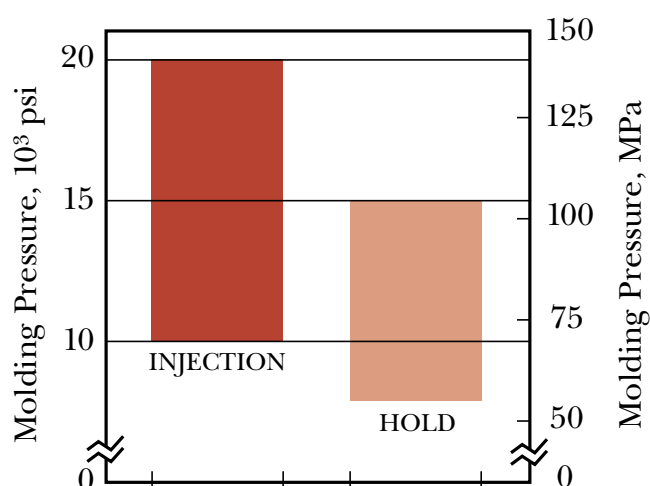

Cushion

The use of a nominal cushion (1/8 inch suggested) reduces material residence time in the barrel and helps accommodate machine variations.

Cycle Time

When adjusting a cycle, attempts should be made to use a fast injection speed, a minimum holding time to achieve gate freeze-off and a short cooling time. ULTEM® resin can frequently provide a significant reduction in cycle time over other thermoplastics and thermosets. The most important factor influencing cycle time is part thickness, as depicted in ■ FIGURE 6-9.

■ FIGURE 6-9

ULTEM® resin cooling time vs. wall thickness.

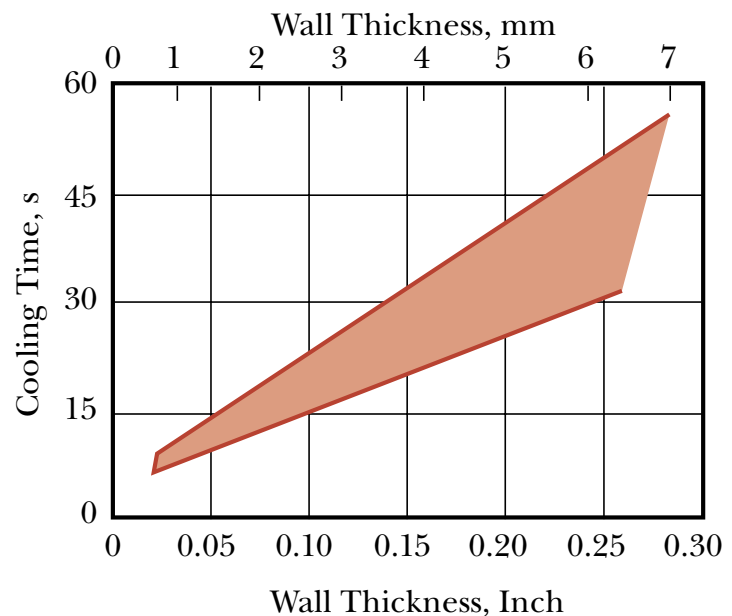

Flow Length as a Function of Temperature and Pressure

Although high melt temperatures are required, ULTEM® resin can be molded with conventional equipment. ULTEM® resin demonstrates a broad melt flow range, which can increase the latitude for the molder to fill thin walls and long flow parts. Melt temperatures should be between 640 and 750°F (338 and 398°C).

■ FIGURES 6-10 through 6-13 show the effects of melt temperature and injection pressure on the flow length of ULTEM® 1000 resin at various wall thicknesses. ■ FIGURE 6-14 on page 41 compares the effect of material temperature on flow length of ULTEM® 1000 resin vs. other thermoplastic resins.

■ FIGURE 6-10

ULTEM® 1000 resin flow length at 675°F (357°C).

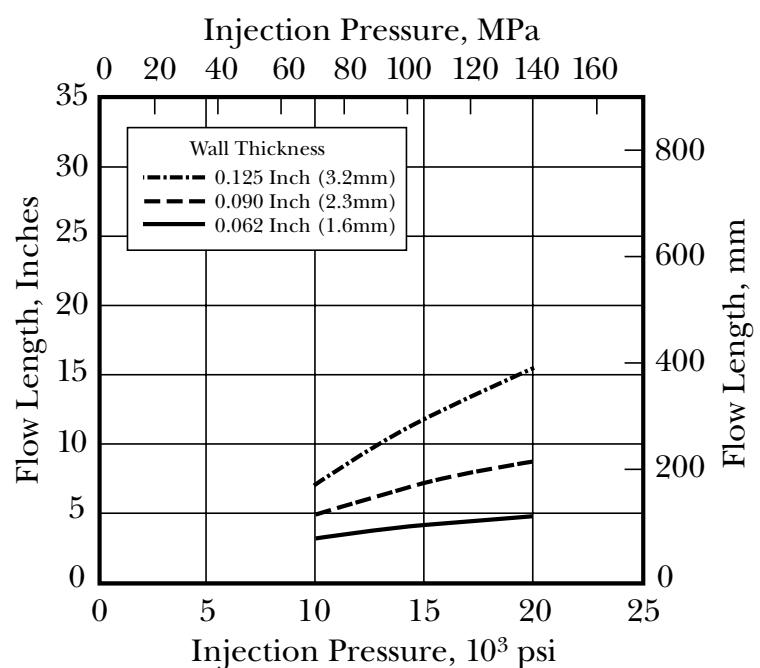

■ FIGURE 6-11

ULTEM® 1000 resin flow length at injection pressure of 10,000 psi (69 MPa).

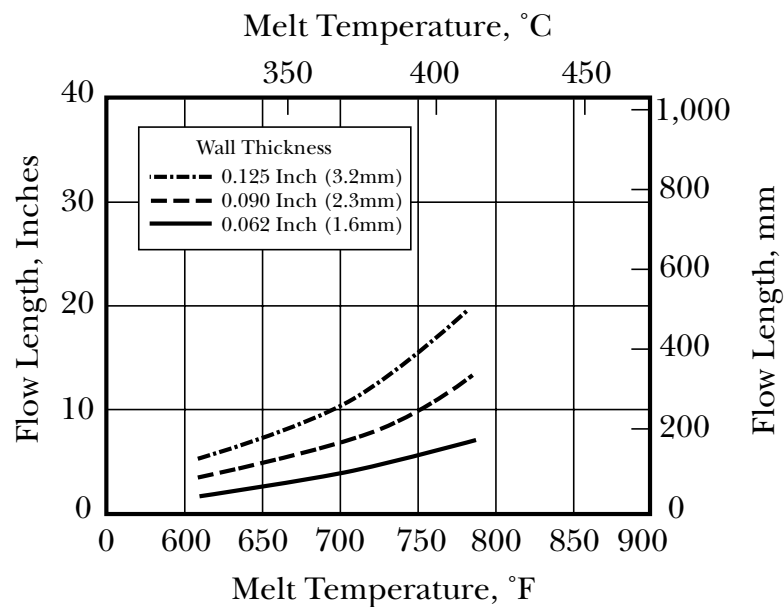

■ FIGURE 6-12

ULTEM® 1000 resin flow length at 750°F (399°C).

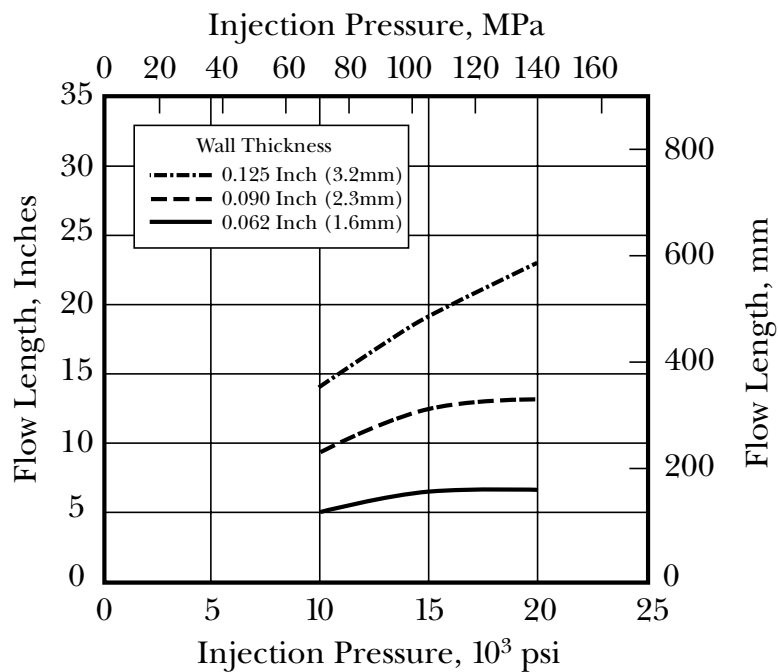

■ FIGURE 6-13

ULTEM 1000® resin flow length at injection pressure of 20,000 psi (138 MPa).

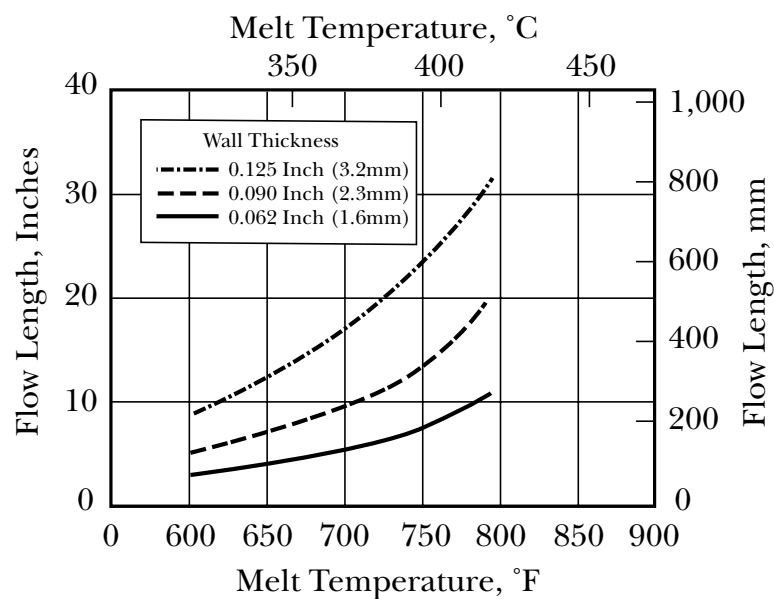

■ FIGURE 6-14

Effect of melt temperature on flow length of ULTEM® 1000 resin vs. other thermoplastics.

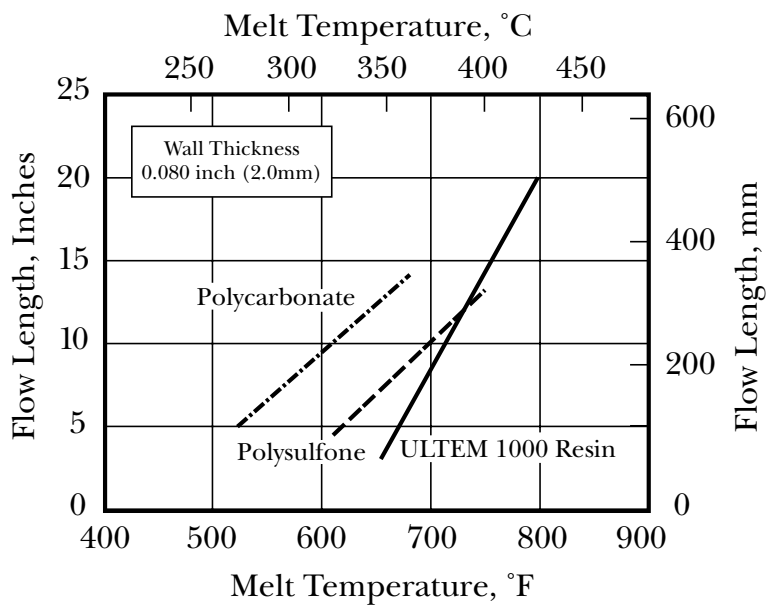

Purging

Thorough purging is essential when changing to or from ULTEM® resin in machines used for other plastics. Since ULTEM® resin's 640 to 750°F (338 to 398°C) processing temperature is well above the degradation level of virtually all other thermoplastics, it is imperative that all traces of other polymers are removed to avoid contamination resulting in black specks.

A number of different materials have been found to be effective purging compounds for ULTEM® resin including:

- HDPE (high density polyethylene); extrusion grade with a melt index of 0.30 to 0.35 g/10 min.
- Glass-reinforced LEXAN® resins are purging compounds in the 450 to 700°F (232 to 371°C) range. Drying is not required for purging.
- For non-reinforced and reinforced grades, begin purging at processing temperature and reduce barrel temperatures to approximately 500°F (260°C) while continuing to purge.

Styrenes and acrylic resins should not be used in high-heat purging. Chemical purging compounds are also not suggested.

Shutdown and Start-Up

When shutting down the machine, the hopper should be shut off at the throat and the machine run until all residual resin is run out of the barrel. The screw should be left in its forwardmost position with the barrel heaters off. Alternatively, heaters can be banked at 350°F (176°C) for long periods of time for the ULTEM® 1000 and 2000 resin series to reduce black-speck contamination during start-up.

When starting up the machine, set the barrel heaters to normal processing temperatures, extrude until residual material is completely purged and begin molding. The initial shots should be checked for contaminants in the molded parts.

Regrind

Reground sprues, runners and non-degraded parts may be added to the virgin pellets up to a level of 25%. Grinder screen sizes should be at least 5/16 to 3/8 inch (7.9 mm). If a smaller size is used, too many fines could be generated, creating molding problems such as streaking and burning. It is important to keep the ground parts clean and to avoid contamination from other materials. Drying time should be increased since regrind will not be the same size as virgin pellets, and therefore water diffusion may be different.

7 Secondary Operations

Although most parts made from ULTEM® PEI resin are molded as finished components, the design and ultimate use of certain parts may require machining, assembly or finishing operations. ULTEM® resin makes a wide variety of secondary operations available to the design engineer. General recommendations for these operations are as follows:

7.1 Welding

Welding is a commonly used permanent assembly technique for engineering thermoplastics. ULTEM® resin can be welded by using different processes:

- Vibration Welding
- Ultrasonic Welding, at amplitudes above 30 μm (0-peak)

- Induction Welding
- Hot Plate Welding is not recommended due to ULTEM® resin sticking at melt temperatures, ($\pm 400^\circ\text{C}$)

7.2 Adhesives

Parts made from ULTEM® PEI resin can be bonded together or to dissimilar materials using a wide variety of commercially available adhesives. Because adhesive bonding involves the application of a chemically different substance between two parts, the end use environment of the assembled unit is important in selecting an adhesive.

Recommended adhesive types for ULTEM® resin are:

- Epoxy adhesives
- Polyurethanes adhesives
- Silicones adhesives
- Care should be taken with cyanoacrylates and acrylic systems which are aggressive for ULTEM® resin. Exposure to these solvents might lead to stress cracking

7.3 Mechanical Assembly

Mechanical assembly techniques are widely used with ULTEM® resin parts. For unreinforced ULTEM® resin grades, the classical rules for amorphous engineering thermoplastics apply. For highly reinforced ULTEM® resin grades, the use of special thread cutting screws is advised because of the low elongation at break. The different mechanical assembly techniques that can be used can be summarized as follows:

- Inserts, installation by heat or ultrasonics are the preferred techniques. Press and expansion inserts give radial stresses. Overmolding and external threaded inserts are also possible.
- Screws by thread forming or thread cutting. Thread forming screws with low flank angle for reduced radial stresses are preferred. Hole (0.85 times screw diameter) and screw should be circular (not trilobular/square). Boss diameter should be 2.5 times screw outer diameter.
- All types of rivets can be used; be aware of high stresses with some pop rivets.
- Staking is possible, with ultrasonic staking being more practical than heat staking.
- Snap fit assembly

7.4 Painting

A wide variety of colors and textures can be applied to ULTEM® resin using commercially available organic paints and conventional application processes. Painting is an economical means of enhancing aesthetics and providing color conformity.

General recommendations for painting ULTEM® resin are:

Pre-treatment

- Hand washing the part with cleaning agents based on alcohol or aliphatic hydrocarbons or:
- Power washing the part with cleaning agents based on detergents dissolved in water, acidic by nature, neutral or alkaline

Paint selection

- Paint selection is determined by the desired decorative effect, specific functional needs and the application technique to be employed.

- Coatings can also help to minimize color degradation.
- Conductive coatings offer shielding against radio frequency interference (RFI) or electromagnetic interference (EMI).
- A variety of conventional and waterborne paints can be successfully applied to ULTEM® resin. Generic types are: Acrylic, Alkyd, Epoxy, Polyester, Polyimide, Polyurethane
- If the ULTEM® resin application is working under high temperature conditions, the selected paint must offer equal high temperature performance.

Paint solvents

It is important that solvent formulations are considered when selecting a paint for use with ULTEM® resin. It can be extremely difficult to achieve an ideal match between solvent and substrate.

7.5 Metallization

Metallization of plastics is normally undertaken for decorative or functional reasons. Properties usually associated with metals such as reflectiveness, abrasion resistance, electrical conductivity and decorative surfaces can be added through metallization.

General recommendations for the metallization of ULTEM® resin are:

Pre-treatment

Typically unreinforced ULTEM® resin does not need a basecoat or lacquer primer layer before metallization because of the good surface quality of ULTEM® resin after molding. However, a surface activation pre-treatment is required in most cases. Cleaning with cloth or solvents is not recommended because of sensitivity to scratches that can be seen after metallization.

The best method is to keep the moldings clean and to metallize the parts as soon as possible after molding, or store them in clean containers.

Metallization methods

- Vacuum metallization through Physical Vapor Deposition. Physical Vapor Deposition is the depositing of an evaporated metal, mostly aluminum, on a substrate. To achieve evaporation, the pure metal is heated in a deep vacuum.
- Vacuum metallization through sputtering (Plasma Enhanced Chemical Vapor Deposition, PE-CVD). Sputtering or PE-CVD also take place in a vacuum. With high voltage equipment, a field is created between the sample's grounded carrier and a negative electrode: the metal target that has the function of a metal or an alloy donor.

- **Plating**

This can be done either by electroless plating without the addition of current to the galvanic process and/or followed by electroplating where current is used to effect an electrolytic deposition of metals coming from a dissolved metal salt.

- ***Electroless plating***

A non-conductive plastic is coated with a continuous metallic film by etching the plastic. This creates micro cavities which make interlocking possible. Chemical bond plating is a special etching technique which is particularly suitable for use with ULTEM® resin. In this technique, a permanganate etch opens the ULTEM® resin molecule imide ring, and allows copper to enter the molecule. A very high level of adhesion can be established with this technology. This technique is often used for EMI shielding and for Molded Interconnect Devices, MIDs. For EMI shielding an electroless copper layer of 1-2 µm is applied with a finish of 0.5 µm of electroless nickel. For a MID application where the molded part becomes a circuit board, an additional copper layer is applied by electroplating.

- ***Electroplating***

After the application of a conductive metal layer on the plastic, a further electrolytic deposition of selected metals on top of this layer can be done. Most frequently used metals are either chrome, nickel or gold in varying thicknesses.

- **Dichroic coating**

ULTEM® resin is very suitable for use with dichroic coatings which reflect visible light but allow the transmission of infra-red rays. By applying multiple coating layers with different refraction indices, light with specific wavelengths can be filtered. The dichroic coating process also takes place in a vacuum vessel, and is used in high heat generating lamps such as small halogen lamps and dentist lamp reflectors.

After treatment

Due to the reactive nature of aluminum to humidity, and the ultra-thin layer thickness, aluminum must be protected against environmental influences.

There are two systems that are most commonly used to provide this protection:

- Plasil/Glipoxan top layer: this silicon-based monomer layer is applied in the vacuum
- Clear coat top layer

Note

General information on Secondary Operations like welding, mechanical assembly, bonding painting and metallization of engineering thermoplastics can be found in the following GE Plastics brochures:

- Assembly guide
- Design guide
- Painting guide
- Metallization guide

Addresses

- More information relative to this **ULTEM® PEI Resin Product Guide** can be found on:

www.geplastics.com/resins/materials/ultem.html

- Visit GE Plastics on: www.geplastics.com/resins

European Headquarters

General Electric Plastics B.V.
1 Plasticlaan, P.O. Box 117
NL-4600 AC Bergen op Zoom
The Netherlands
Telephone: (31) 164-292911
Telefax: (31) 164-292940

Central & Eastern Europe Region

General Electric Plastics
Donau City-Strasse 6/8
A-1220 Vienna
Austria
Telephone: (43) 1-815720311
Telefax: (43) 1-815720320

Benelux Sales Region

General Electric Plastics B.V.
Gagelboslaan 4
NL-4623 AD Bergen op Zoom
The Netherlands
Telephone: (31) 164-292391
Telefax: (31) 164-291725

United Kingdom

GE Plastics Limited
Old Hall Road
Sale
Cheshire M33 2HG
United Kingdom
Telephone: (44) 161-9055000
Telefax: (44) 161-9055119

Germany

General Electric Plastics GmbH
Eisenstrasse 5
D-65428 Rüsselsheim Germany
Telephone: (49) 6142-6010
Telefax: (49) 6142-65746

France

General Electric Plastics France S.À.R.L.
Z.I. St. Guénault B.P. 67
F-91002 Evry-Cedex France
Telephone: (33) 1-60796900
Telefax: (33) 1-60775653



Italy

General Electric Plastics Italia S.p.A.
Viale Brianza, 181
I-20092 Cinisello Balsamo (Milano)
Italy
Telephone: (39) 02-618341
Telefax: (39) 02-61834211

Russia

General Electric International A/O
Kosmodamianskaia Nab, 6th floor
Building 1
115054 Moscow Russia
Telephone: (7) 095-9357278
Telefax: (7) 095-9357231

Spain

General Electric Plastics Ibérica S.A.
Avenida Diagonal, 652-656
Edificio D. Planta 3
08034 Barcelona Spain
Telephone: (34) 93-2521600
Telefax: (34) 93-2802619

Sweden

GE Polymerland Sweden A.B.
Solna Strandväg 98, Box 324
17175 Stockholm Sweden
Telephone: (46) 0-855950180
Telefax: (46) 0-855950185

Denmark

GE Polymerland ApS
Groningen 25
DK-1270 Copenhagen Denmark
Telephone: (45) 33-979570
Telefax: (45) 33-324910

Finland

GE Polymerland Finland O.Y.
Virnatie 5
SF-01300 Vantaa
Finland
Telephone: (358) 9-47618800
Telefax: (358) 9-47618820

Turkey

GE Plastics Turkey
Dudullu Organize Sanayi Bolgesi
2.Cadde No 173
81250 Umraniye
Istanbul Turkey
Telephone: (90) 216-3651565 (pbx)
Telephone: (90) 216-3654959 (pbx)
Telefax: (90) 216-3650115

AMERICAS

United States

GE Plastics
One Plastics Avenue
Pittsfield, MA 01201 USA
Telephone: (413) 448-7110
Cable: GEPLASTICS

California

GE Polymerland, Inc.
4160 Hacienda Dr.
Pleasanton, CA 94588
Telephone: (510) 414-8992
Telefax: (925) 463-7282

GE Polymerland, Inc.
7700 Irvine Center Drive
Suite #450
Irvine, CA 92618
Telephone: (714) 328-5188
Telefax: (949) 754-1639

Illinois

GE Polymerland, Inc.
2200 Cabot Drive
Suite 102
Lisle, IL 60532
Telephone: (630) 248-0706
Telephone: (630) 505-2500
Telefax: (630) 505-2528

Massachusetts

GE Polymerland, Inc.
One Plastics Ave.
Pittsfield, MA 01201
Telephone: (413) 496-2558
Telefax: (413) 448-7176

Michigan

P.O. Box 5011
Southfield, MI 48086-5011
H 25900 Telegraph Road
Southfield, MI 48034
Telephone: (810) 351-8000

Ohio

GE Polymerland, Inc.
Suite 660, 6000 Lombardo Center
Seven Hills, OH 44131
Telephone: (216) 573-7460
Telefax: (216) 524-4409

Connecticut

41 Woodford Ave.
Plainville, CT 06062
Telephone: (860) 747-7433
Telefax: (860) 747-7432

North Carolina

GE Polymerland, Inc.
9930 Kincey Ave.
Huntersville, NC 28078
Telephone: (704) 641-1075
Telefax: (704) 992-4937

Puerto Rico

General Computer Building
P.O. Box 2010
Bayamon Puerto Rico 00960
Road 174, No. 101
Minillas Industrial Park
Bayamon Puerto Rico 00959
Telephone: (787) 288-2340
Telefax: (787) 288-2348

Brazil

GE Plastics South America S/A
Av. das Nacoes Unidas, 12995-20 andar
Brooklin Novo
04578-000 São Paulo, SP Brazil
Telephone: (55) 11-55052800
Telefax: (55) 11-55051757

Canada

GE Plastics – Canada
General Electric Canada Inc.
2300 Meadowvale Blvd.
Mississauga, Ontario
L5N 5P9 Canada
Telephone: (905) 858-5700
Telefax: (905) 858-5798

Mexico

GE Polymerland
Monte Pelvoux No. 220-2 Floor
Col. Lomas de Chapultepec
MX, D.F. 11000
Telephone: (8) 011-5522846711
Telefax: (8) 011-5522845760

ASIA PACIFIC**Pacific Headquarters**

GE Plastics Pacific HQ
26F, United Plaza, 1468 Nanjing Road
Shanghai 200040, P.R. China
Telephone: (86) 21-32224500
Telefax: (86) 21-62898998

GE Plastics Pacific Pte. Ltd.
#09-00 GE Tower
240 Tanjong Pagar Road
Singapore 0208
Telephone: (65) 220-7022
Telefax: (65) 326-3290

Australia

H GE Plastics (Australia) Pty. Ltd.
175 Hammond Road
Dandenong, Victoria 3175
Australia
Telephone: (61) 3-97037201
Telefax: (61) 3-97948563

GE Plastics (Australia) Pty. Ltd.
57/2 O'Connell Street
Parramatta, New South Wales 2150
Australia
Telephone: (61) 2-96893888
Telefax: (61) 2-96893530

GE Plastics (Australia) Pty. Ltd.
Legal and General Building
206 Greenhill Road
Eastwood, South Australia 5063
Australia
Telephone: (61) 8-82725044
Telefax: (61) 8-82722479

Bangalore India

GE Plastics
Gateway Tower 8th Floor
DLF City Phase III, NH-8
Gurgaon 122002, India
Telephone: (91) 124-5018014

China

GE Plastics Greater China
16F, Plaza 66, 1266 Nanjing Road
Shanghai 200040, P.R. China
Telephone: (86) 21-62881088
Telefax: (86) 21-62880818

GE Plastics China Plant
58 Ai Du Road,
WaiGao Qiao Free Zone
Shanghai 200131, P.R. China
Telephone: (86) 21-50460000
Telefax: (86) 21-50460100

LNP Pacific Office
26F, United Plaza,
1468 Nanjing Road (W)
Shanghai 200040, P.R. China
Telephone: (86) 21-32224500
Telefax: (86) 21-62898998

LNP Engineering Plastics (M) Co., Ltd.
Shanghai Rep. Office, 7E,
Majesty Building,
138 Pudong Avenue, Shanghai 200120
Telephone: (86) 21-58829025
Telefax: (86) 21-58829027

GE Plastics – Nansha
No. 1 Plastics Ave, Nansha ETDZ
Panyu District, Guangzhou
511458, P.R. China
Telephone: (86) 20-84980148
Telefax: (86) 20-84980202

Hong Kong

GE Plastics Hong Kong Limited
Room 1008, Tower I, The Gateway
25 Canton Road, Tsimshatsui
Kowloon, Hong Kong
Telephone: (85) 3-26290853
Telefax: (85) 3-26290804

LNP Engineering Plastics (Asia) Pte. Ltd.
Room 1008, Tower 1, The Gateway,
25 Cannon Road
Tsimshatsui, Kowloon
Telephone: (85) 2-26290812
Telefax: (85) 2-26290800

India

GE Plastics India Limited
Plastics Avenue
P.O. Jawahar Nagar
Baroda – 391320
Gujarat, India
Telephone: (91) 265-2232147/2232177
Telefax: (91) 265-2232144

GE Plastics India Limited
Millers' Boulevard
70/2, Millers Road
Bangalore – 560052
Karnataka, India
Telephone: (91) 80-2263144/3145
Telefax: (91) 80-2254247

GE Plastics – Haryana
8th Floor – Gateway Towers
DLF City Phase III – NH 8
Gurgaon – 122002
Haryana, India
Telephone: (91) 124-5018001
Telefax: (91) 124-5018021/8022

GE Plastics – Mumbai
Solitaire Corporate Park Building 7
8th Floor, Unit 1, New Link Road
Mumbai 400093, India
Telephone: (91) 22-56972390
Telefax: (91) 22-56972383

Indonesia

GE Plastics – Indonesia
KH Mas Mansyur Kav. 126
Jakarta 10220, Indonesia
Telephone: (62) 21-5744980
Telefax: (62) 21-5747101

Japan

GE Plastics Japan, Ltd.
1015 Aza Sumiyakizawa
Hodozawa, Gotemba-shi
Shizuoka 412, Japan
Telephone: (81) 550-892323

GE Plastics Japan, Ltd.
Tokyo Office
Nihombashi Hamacho Park Bldg.
2-35-4, Nihombashi-Hamacho
Chuo-ku, Tokyo 103, Japan
Telephone: (81) 3-56956800
Telefax: (81) 3-56954859

GE Plastics Japan – Moka
2-2 Kinugaoka, Moka-Shi
Tochigi-Ken 321-4392, Japan
Telephone: (81) 285-802111
Telefax: (81) 285-802156

LNP Engineering Plastics, Japan
Nihombashi, Hamacho Park Building,
2-35-4, Nihombashi-Hamacho,
Chuo-Ku
Tokyo 103-0007, Japan
Telephone: (81) 5695-4606
Telefax: (81) 5695-4859

GEM Polymers Ltd. Osaka Factory
5, Takasago, 1-Chome, Takaishi-City
Osaka 5920001, Japan
Telephone: (81) 722-680457
Telefax: (81) 722-680458

Korea

H GE (USA) Plastics Korea Co., Ltd.
231-8, Nonhyundong Kangnamku
Seoul 135-010, Korea
Telephone: (82) 2-510-6250/6000
Telefax: (82) 2-510-6666/6224

GE Plastics Korea – Chungju
240-18, Mokhaeng-Dong, Chungju City
Chungbuk 380240, Korea
Telephone: (82) 43-8508110
Telefax: (82) 43-8508054

LNP Engineering Plastics, Korea
231-8, Nonhyun-Dong, Kangnam-Ku
Seoul 135010, Korea
Telephone: (82) 2-5106789
Telefax: (82) 2-5106461

Malaysia

GE Plastics Malaysia
Lot 762 Jalan Haji Sirat,
42100 Klang, Selangor Darul Ehsan
Telephone: (60) 3-32913133
Telefax: (60) 3-32903133

LNP Engineering Plastics (Asia) Pte. Ltd.
Lot 35, Persiaran Bunga Tanjung 2,
Senawang
Industrial Park, 70400 Seremban,
Negeri Sembilan
Darul Khusus, Malaysia
Telephone: (60) 6-6767700
Telefax: (60) 6-6786518

Singapore

GE Plastics Singapore Pte. Ltd.
23 Benoi Road
Singapore 629895
Telephone: (65) 8610081
Telefax: (65) 6-610709

GE Plastics – Singapore
Sales & Marketing Office
80 Anson Rd., #38-00 IBM Towers
Singapore 079907
Telephone: (65) 223-7022
Telefax: (65) 223-7033

LNP Engineering Plastics (Asia) Pte. Ltd.
171 Chin Swee Road #03-07, San Centre
Singapore 169877
Telephone: (65) 6535-2022
Telefax: (65) 6536-5022

Taiwan

GE Plastics, Taiwan
8F-1, 35 Min Chuan E. Road Sec. 3
Taipei, Taiwan, R.O.C.
Telephone: (886) 2-5092124
Telefax: (886) 2-5091625

LNP Engineering Plastics Taiwan Inc.
13F, Room E1, No. 168,
Tun Hua North Road
Taipei 105
Telephone: (88) 6-227147000
Telefax: (88) 6-225453305

Thailand

GE Plastics – Thailand
21st Floor Thaniya Plaza Bldg.
52 Silom Road
Bangkok 10500, Thailand
Telephone: (66) 2-2312323
Telefax: (66) 2-2312322
H Application Development Center

GE Plastics (Thailand) Company Limited
64/22 Moo 4 Tumbol Pluak Daeng,
Amphur Pluak Daeng, Rayong 21140
Thailand
Telephone: (66) 38-95523542
Telefax: (66) 38-955244

Notes

imagination at work



CYCOLAC® Resin

CYCOLOY® Resin

GELOY® Resin

LEXAN® Resin

NORYL® Resin

ULTEM® Resin

VALOX® Resin

VERTON® Resin

STARFLAM® Resin

SUPEC® Resin

XENOY® Resin

XYLEX™ Resin

GE Plastics

General Electric Company
One Plastics Avenue
Pittsfield, MA 01201
800.845.0600
www.geplastics.com

To Find Out More

Call our toll-free numbers:

USA:	800-845-0600
Europe:	00-800-1234-4000
China Mainland:	800-820-4377
Japan:	81-285-80-2370
Korea:	82-080-850-6000
Hong Kong:	800-900-956
Taiwan:	0080-86-1002
Singapore:	800-860-0002

E-mail us at:

GELIT@gepex.ge.com

Visit:

www.geplastics.com/resins/materials/ultem.html

imagination at work

